

NPN

New Product News



MAXISPEED

**Quick Changeable Solid Carbide Head
for Multiple Machining**

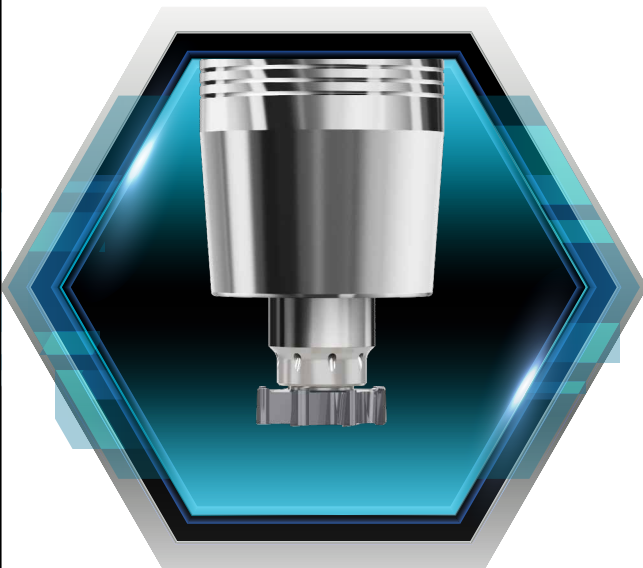

KEY POINT

TaeguTec has introduced a multi-purpose, head-exchangeable line for various applications.

MAXI-SFEED is an optimized slotting line dedicated to the machining of various machinery components and other slotting applications in mini-sized operations that out perform equivalent insert types.

TaeguTec's unique yet simple design allows for precise and rigid mounting of a head exchangeable slotting cutter with the use of only one clamping screw, thereby eliminating the need for additional setup time. Furthermore, it is a more productive solution compared to the slotting insert type, due to the cutter's additional cutting edges being applied to the same diameter.

In addition to slotting, the head-exchangeable head can be used in other machining applications including facing and threading.

For further technical questions, please contact TaeguTec's product manager.



Features

- Simple and robust precision mounting system

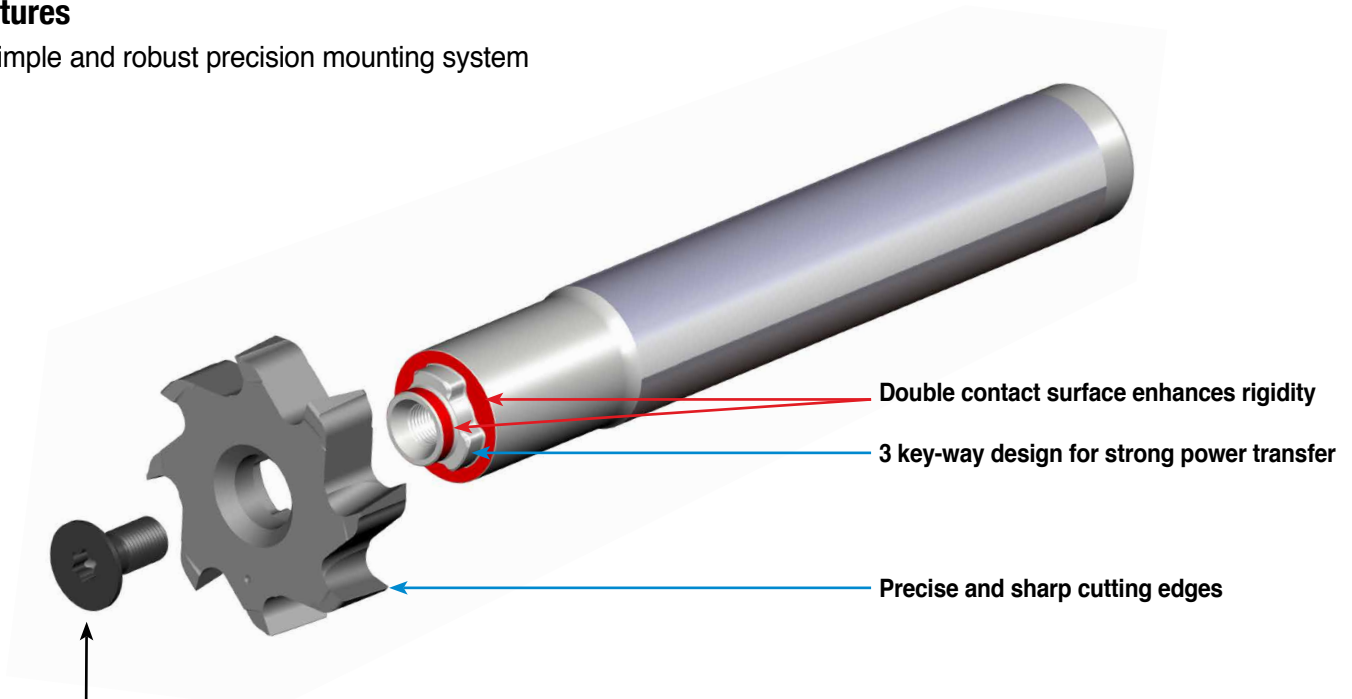

Easy fastening one screw set-up
- No setup time required

- More cutting edges maximize productivity

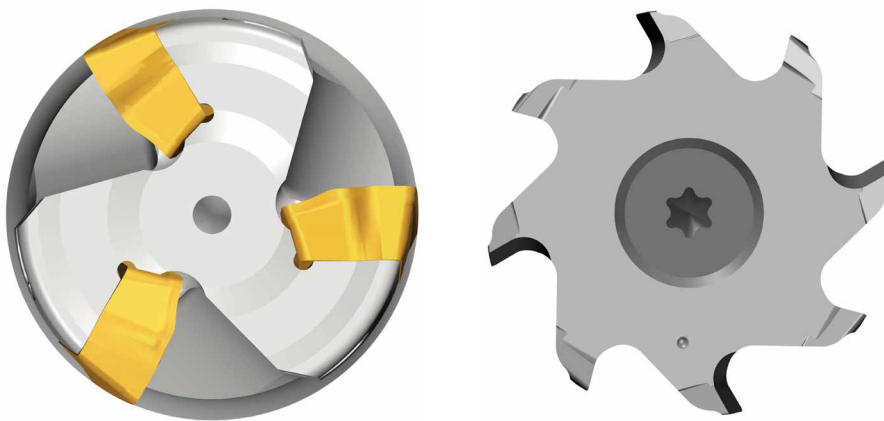

- Suited for a wide variety of applications :
- Slotting, Facing and Threading

■ Wider usage due to several diameters and thicknesses

Slotting (TR-S)

Tool diameter (mm)	W (slot width) (mm)	T-max (mm)
24.7	3-8	5.5
31.7	3-8	8
39.7	4-10	11

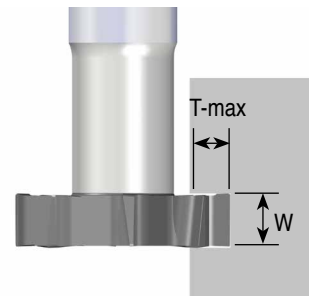

Facing (TR-F)

Tool diameter (mm)	Max. ap (mm)	Number of teeth
24.25	8	6
31.25	8	8
39.25	10	10

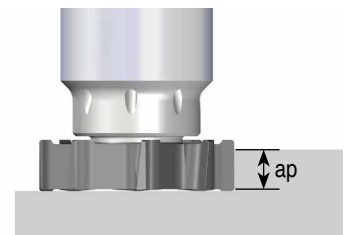

Threading (TR-T)

Tool diameter (mm)	Screw profile	Number of teeth
24.7	M60 / W55	6
31.7	M60 / W55	8
39.7	M60 / W55	10

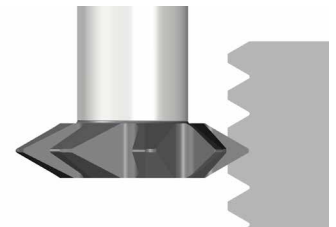

Attention

When internal coolant is applied by combining the TR-F head with the TR-F-C holder, the arrows shown on the head and holder must be positioned opposite to each other (as shown below) in order to ensure a smooth coolant flow to the cutting edge.

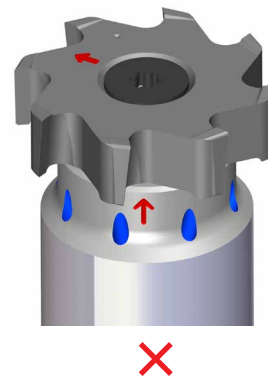
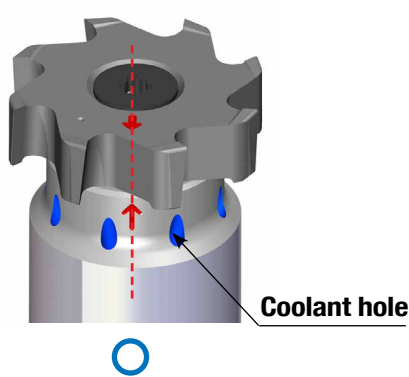

TR-T-W55



Interchangeable solid carbide threading heads – 55° partial profile

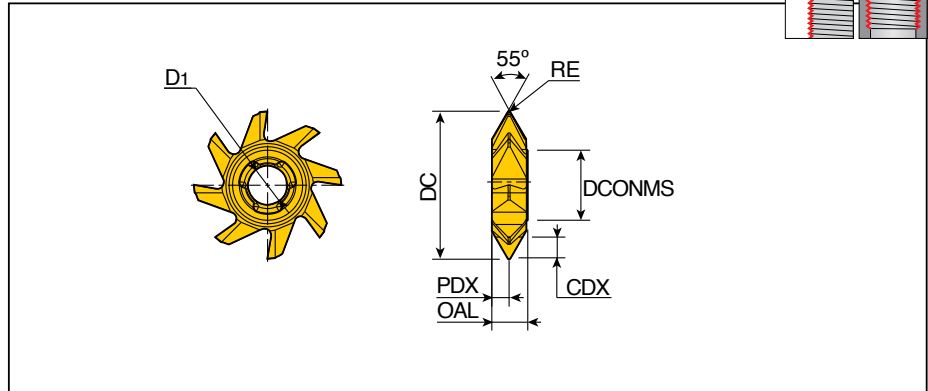

Designation	TPI	Dimension (mm)									Grade
		DC	DMIN	PDX	RE	D ₁	CDX	OAL	ZEFP	DCONMS	
TR13-T-24.7-W55-3T	5-3	24.7	36	2.2	0.5	7.5	3.5	7.7	6	13	●
15-T-31.7-W55-4T	6-4	31.7	46	3.7	0.5	8.4	4.7	7.7	8	15	●
17-T-39.7-W55-3T	4-3	39.7	57	4.5	0.8	9.8	6.2	9.5	10	17	●

- TPI: Threads per inch
- ZEFP: Peripheral effective cutting edge count

●: Standard items

TR-T-M60



Interchangeable solid carbide threading heads – 60° partial profile

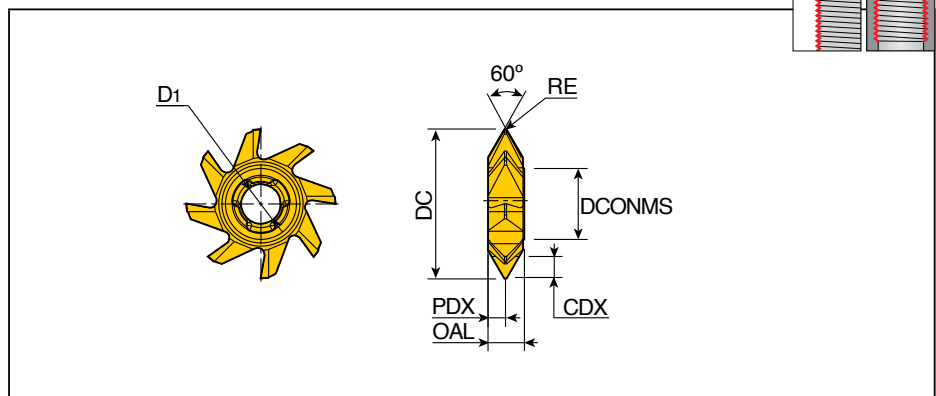
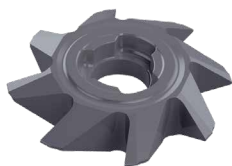

Designation	TPI		Dimension (mm)									Grade
	TP(mm)	TPI	DC	DMIN	PDX	RE	D ₁	CDX	OAL	ZEFP	DCONMS	
TR13-T-24.7-M60-5P	3-5	5-3	24.7	36	2.2	0.2	7.5	3.5	7.7	6	13	●
15-T-31.7-M60-6P	4-6	6-4	31.7	46	3.7	0.3	8.4	4.7	7.7	8	15	●
17-T-39.7-M60-8P	6-8	4-3	39.7	57	4.5	0.4	9.8	6.2	9.5	10	17	●

- TP: Threads pitch, TPI: Threads per inch
- ZEFP: Peripheral effective cutting edge count

●: Standard items



TR

Slotting & threading holders

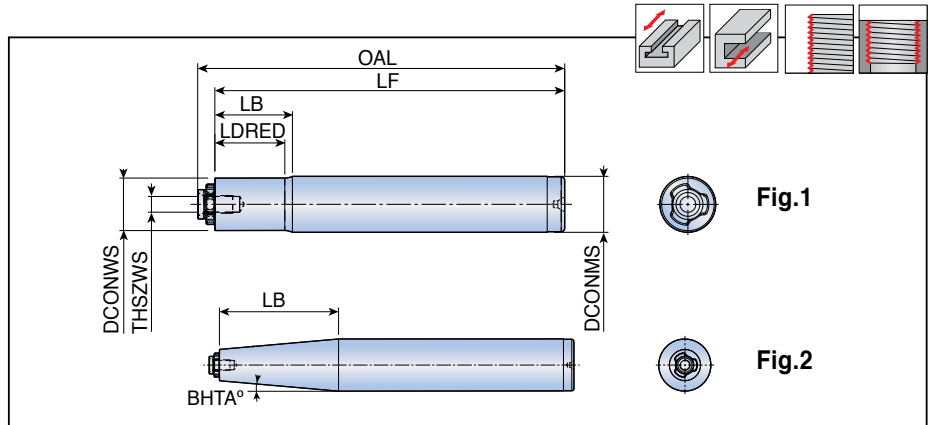

Designation	Dimension (mm)								Coolant	Fig.	Insert
	DCONMS	DCONWS	LB	LF	OAL	THSZWS	LDRED	BHTA°			
TR13-16-L100	16	13	16.6	100	104.35	M4x0.5	13.0	-	x	1	TR-S.. TR-T..
15-16-L100	16	15	18.2	100	104.90	M5x0.5	16.0	-	x	1	
15-16-L130	16	15	18.2	130	134.90	M5x0.5	16.0	-	x	1	
17-20-L140	20	17	23.8	140	146.00	M6x0.5	20.2	-	x	1	
15-25-TC170	25	15	57.2	170	174.90	M5x0.5	-	5	x	2	

Spare parts

Designation	Screw	Wrench	Wrench handle		
TR13	TS 40T098/HG-P	BLD IP15/S7	SW6-T		
TR15	TS 50T110/HG-P	BLD IP20/S7	SW6-T		
TR17	TS 60T130/HG-P	BLD IP20/S7	SW6-T		

TR-F-C



Facing holders

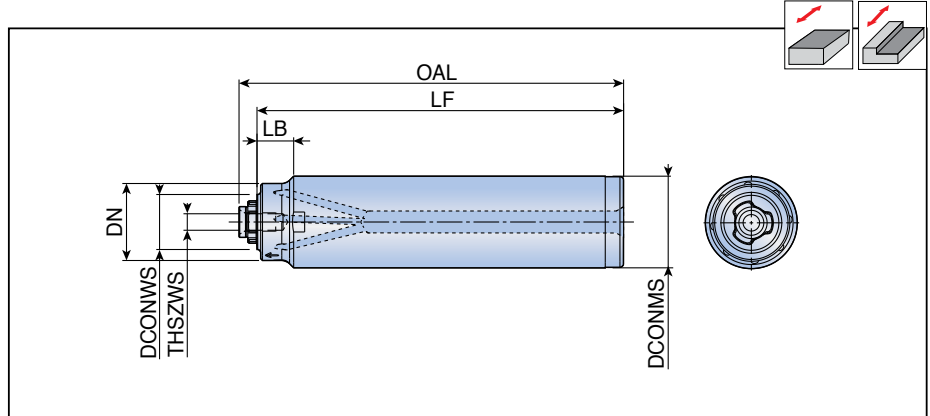

Designation	Dimension (mm)							Coolant	Insert
	DCONMS	DCONWS	LB	LF	OAL	THSZWS	DN		
TR13-20-L100-F-C	20	13	10	100	104.35	M4x0.5	16	●	TR-F....
13-25-L100-F-C	25	13	12.5	100	104.35	M4x0.5	16	●	
15-25-L100-F-C	25	15	10	100	104.90	M5x0.5	21	●	
15-32-L110-F-C	32	15	13.5	110	114.90	M5x0.5	21	●	
17-32-L140-F-C	32	17	10	140	146.00	M6x0.5	28	●	
17-42-L140-F-C	42	17	15	140	146.00	M6x0.5	28	●	

Spare parts

Designation	Screw	Wrench	Wrench handle		
TR13	TS 40T098/HG-P	BLD IP15/S7	SW6-T		
TR15	TS 50T110/HG-P	BLD IP20/S7	SW6-T		
TR17	TS 60T130/HG-P	BLD IP20/S7	SW6-T		

Recommended Cutting Conditions

ISO	Material			Vc(m/min)	f (mm/tooth)		
		AISI/SAE/ASTM	HB		TR13	TR15	TR17
P	Non-alloy steel	1020	130-180	120-200	0.04-0.12	0.05-0.15	0.06-0.15
	Low alloy steel	4030	260-300	200-300	0.04-0.12	0.05-0.15	0.06-0.15
	Low alloy steel	3135	HRC 35-40	80-120	0.02-0.06	0.03-0.12	0.04-0.12
	High alloy steel	H13	200-220	100-150	0.03-0.07	0.04-0.12	0.04-0.12
M	Martensitic stainless steel	420	200	100-150	0.02-0.06	0.04-0.12	0.04-0.12
	Austenitic stainless steel	304L	200	80-120	0.02-0.06	0.03-0.10	0.03-0.12
K	Gray cast iron	Class 40	250	150-200	0.04-0.12	0.05-0.20	0.05-0.20
	Malleable cast iron	Class 65 45 12	200	130-180	0.04-0.10	0.05-0.18	0.05-0.18
S	High temp. alloys	Inconel 718	HRC 36-40	20-30	0.015-0.10	0.02-0.12	0.02-0.12
		AMS R56400	HRC40-45	30-40	0.015-0.06	0.02-0.12	0.02-0.12

■ Steel
 ■ Stainless steel
 ■ Cast iron
 ■ Nonferrous
 ■ High temp. alloys
 ■ Hardened steel