



WWW.IWIDIN.COM



NDPG(H) SERIES



GENERAL PURPOSE DRILLS





CONTENTS

NDPG SERIES 4

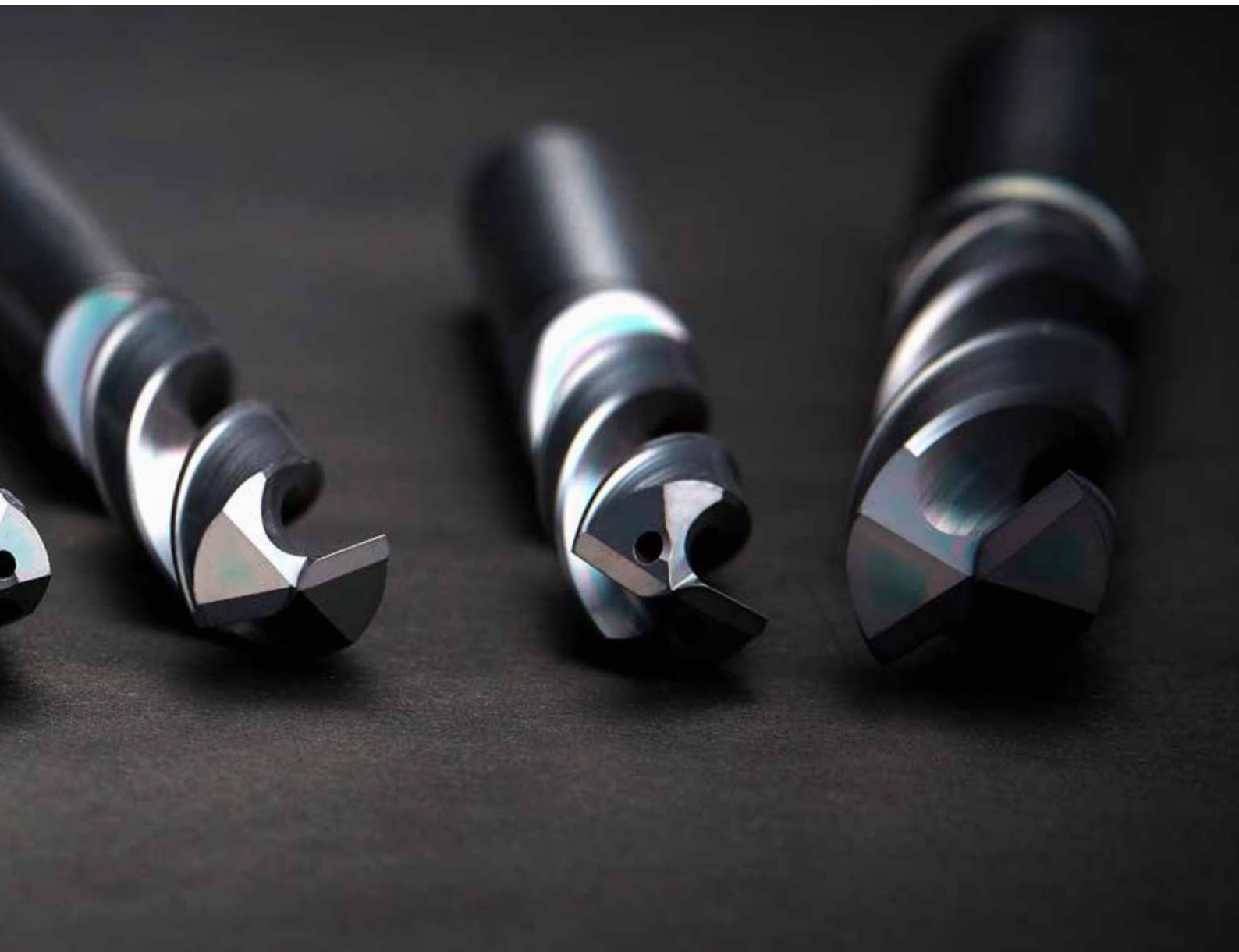

EDP No	Standard	Flute	Geometry	Length			coolant	Margin	Tolerance	Cutting Dia (mm)		Page
				3D	4D	7D				Min	Max	
NDPG503	◆◇	2 Flute		○			External	Single	h7	1	13	9
NDPG504	◆◇				○		External	Single	h7	1	20	11
NDPG507	◆◇					○	External	Single	h7	3	20	14
Recommended Cutting Condition												26



NEW

NDPGH SERIES

6

EDP No	Standard	Flute	Geometry	Length			coolant	Margin	Tolerance	Cutting Dia (mm)		Page
				3D	5D	8D				Min	Max	
NDPGH503	◆◇	2 Flute		○			Internal	Single	m7	3	20	17
NDPGH505	◆◇				○		Internal	Single	m7	3	20	20
NDPGH508	◆◇					○	Internal	Single	m7	3	16	23
Recommended Cutting Condition												26

NDPG SERIES

Characteristics

1. Improved cutting edge design reduces initial cutting forces
2. Flute designed for high hardness and excellent chip evacuation
3. AlCrN coating enhances wear resistance and lubricity
4. Designed for a wide range of workpiece materials

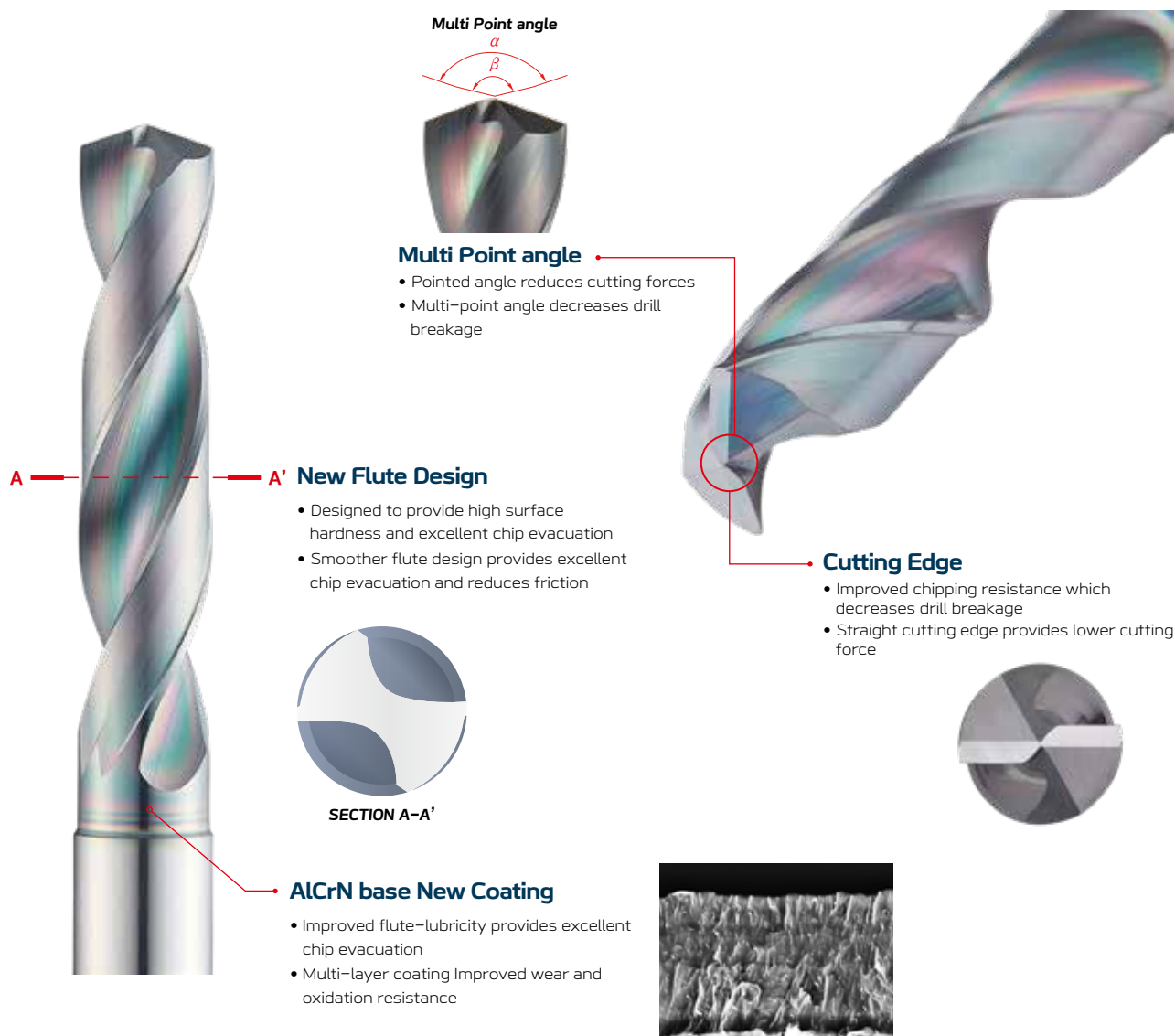

EDP No. System

*If expressed as an integer, the decimal point is omitted

NDP	G	-	5	04	100	-
Series name	Work piece	Coolant Type	Grade	Working Depth	Cutting Dia (Ø)	Standard
NDP : New Dolphin	G (General Purpose)	- : Non Coolant	Grade : 5	03 : 3D	030 : Φ3,0	- : JIS D : DIN
	K (ISO K : Cast Iron)	H : Oil-Hole Coolant		04 : 4D	060 : Φ6.0	
	F (Flat)			07 : 7D	103 : Φ10,3	
	S (Super-alloys & Titanium)					

Case Study

Carbon Steel (1045 Steel)

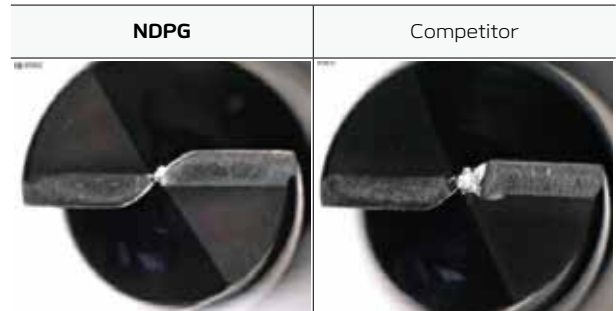
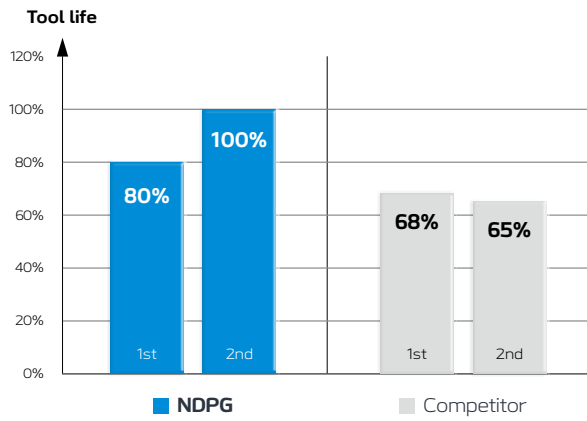

• SPEC : NDPG507060 (D6.0-50/83-6)

• Cutting Condition

Vc	rpm	fn	Feed	Ap	Coolant
120	6,364	0.12	764	30	External

Alloy Steel (4140 Steel)

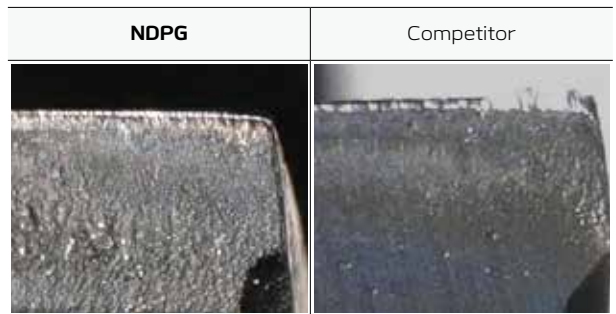
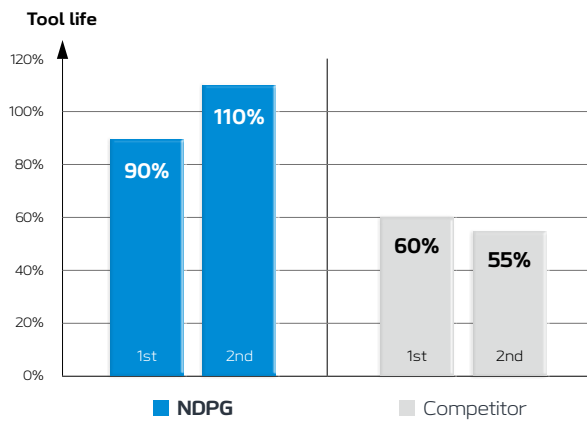

• SPEC : NDPG507060 (D6.0-50/83-6)

• Cutting Condition

Vc	rpm	fn	Feed	Ap	Coolant
100	5,303	0.12	636	30	External

Stainless Steel (304 SS)

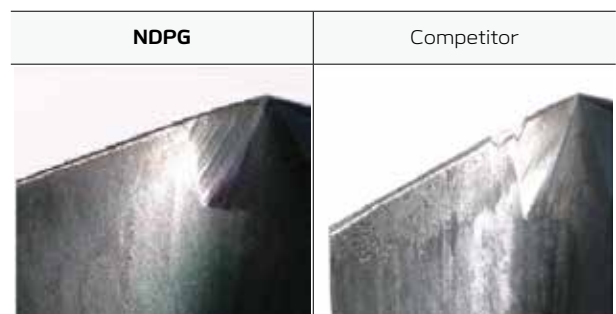
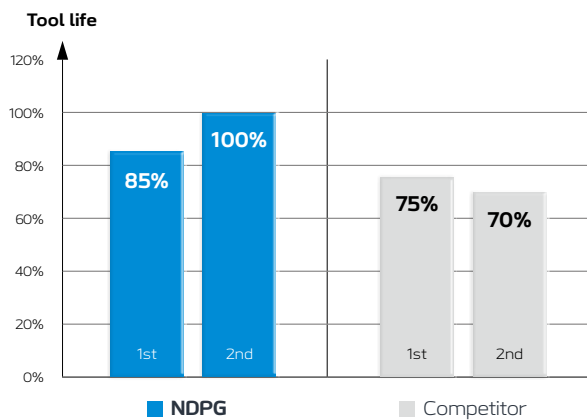

• SPEC : NDPG507060 (D6.0-50/83-6)

• Cutting Condition

Vc	rpm	fn	Feed	Ap	Coolant
30	1,591	0.04	64	5	External

NDPGH SERIES

Characteristics

1. Designed for a wide range of work materials
2. New flute design provides larger volume of fluid to cool the cutting edge
3. XR thinning provides excellent chip evacuation and reduced cutting forces
4. Wider flutes minimizes chip packing

Product Lineup

- 3D : DIN 6537, HB/HE Shank
- 5D : DIN 6537, HB/HE Shank
- 8D : Widin Standard

XR Thinning

- Excellent chip evacuation
- Provides improved chipping resistance and prevents drill breakage
- Streamlined thinning shape reduces cutting forces

New Flute Geometry

- Lower cutting temperatures are possible due to higher volume of coolant
- Excellent chip evacuation

Improved Cooling

existing NDPGH

Reduced Chip Packing

- Wider flute design provides excellent chip evacuation
- Designed to reduce the friction in the flute surface for improved chip evacuation

EDP No. System

*If expressed as an integer, the decimal point is omitted

NDP	G	H	5	05	060	D
Series name	Work piece	Coolant	Grade	Working Depth	Cutting Dia (Ø)	Standard
NDP : New Dolphin	G (General Purpose)	- : Non Coolant	Grade : 5	03 : 3D	030 : Φ3,0	- : JIS
	K (ISO K : Cast Iron)	H : Oil-Hole Coolant		05 : 5D	060 : Φ6.0	D : DIN
	F (Flat)			08 : 8D	103 : Φ10,3	
	S (Super-alloys & Titanium)					

Case Study

Carbon Steel (1045 Steel)

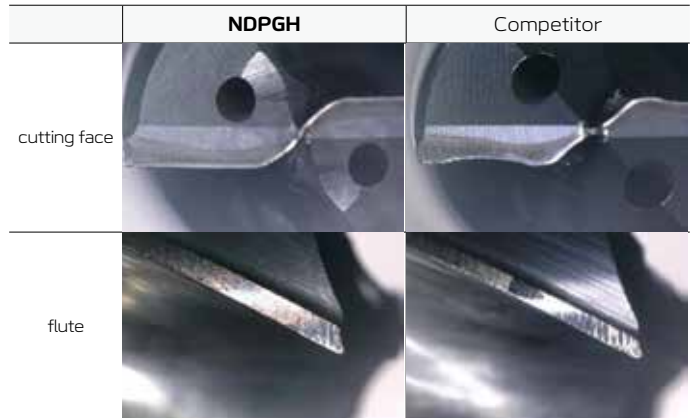
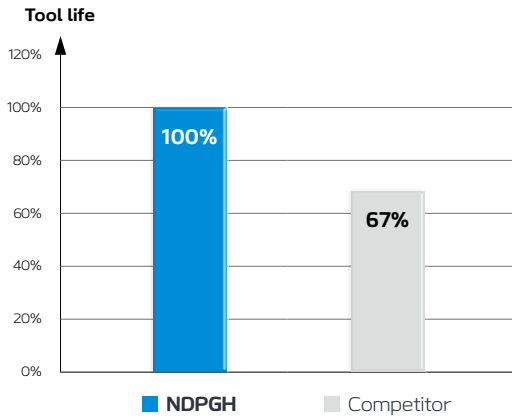

- SPEC : NDPGH505060D (D6.0-44/82-6)
- Cutting Condition

Vc	rpm	fn	Feed	Ap	Coolant
100	5,300	0.24	1,272	30	Inner

Alloy Steel (4140 Steel)

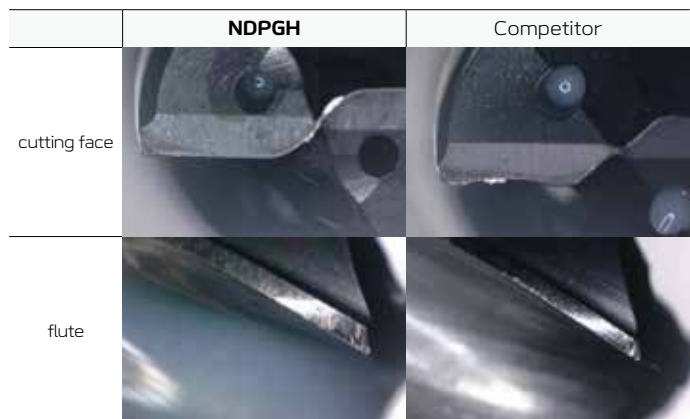
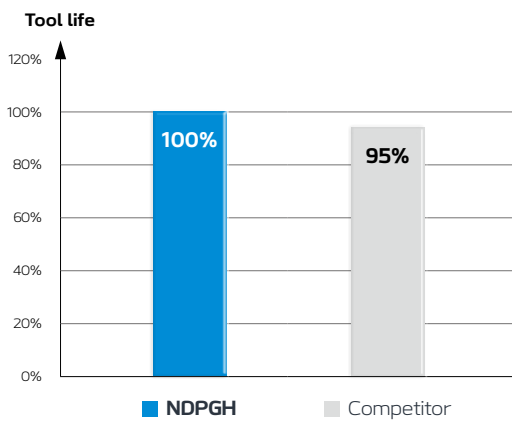

- SPEC : NDPGH505060D (D6.0-44/82-6)
- Cutting Condition

Vc	rpm	fn	Feed	Ap	Coolant
80	4,250	0.20	850	30	Inner

Stainless Steel (304 SS)

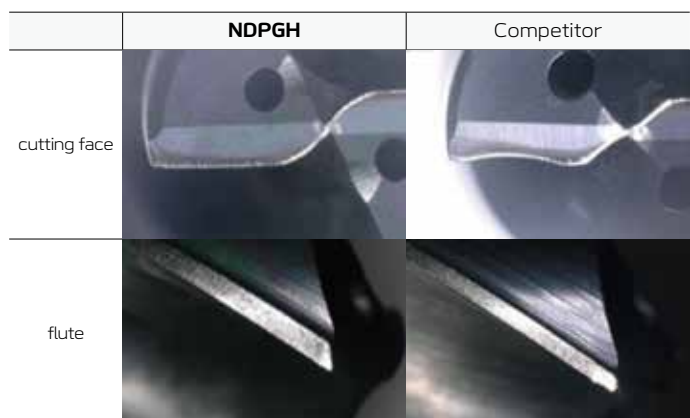
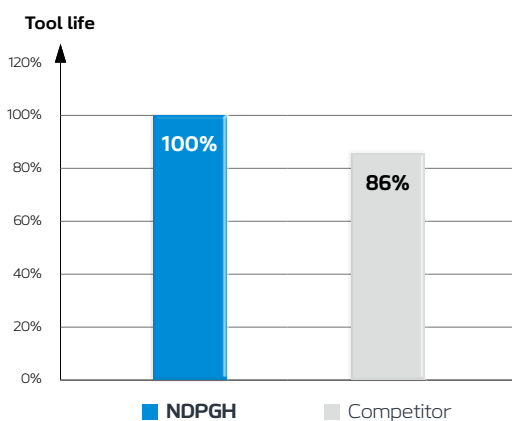



- SPEC : NDPGH505060D (D6.0-44/82-6)
- Cutting Condition

Vc	rpm	fn	Feed	Ap	Coolant
60	3,175	0.14	445	19	Inner

01. NDPG SERIES



◆ : Metric ◇ : Inch

EDP No	Standard	Flute	Geometry	Length			Coolant	Margin	Tolerance	Cutting Dia (mm)		Page
				3D	4D	7D				Min	Max	
NDPG503	◆◇	2 Flute		○			External	Single	h7	1	13	9
NDPG504	◆◇				○		External	Single	h7	1	20	11
NDPG507	◆◇					○	External	Single	h7	3	20	14
Recommended Cutting Condition											26	

NDPG503

NEW DOLPHIN GENERAL PURPOSE DRILL

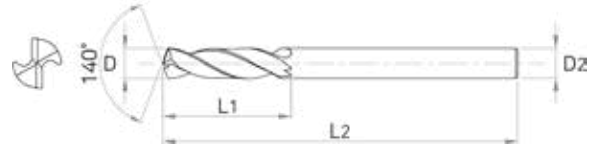
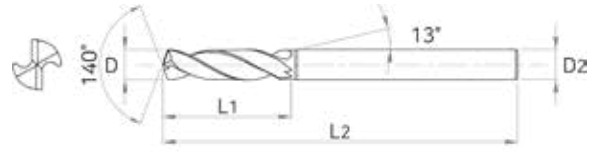

Tolerance

Cutting Dia (mm)		Shank Dia
D1 ~ D3	0 ~ -0,010	
D3,1 ~ D6	0 ~ -0,012	
D6,1 ~ D10	0 ~ -0,015	
D10,1 ~ D13	0 ~ -0,018	h6

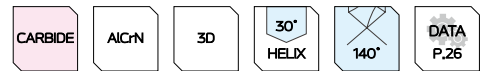

EDP No	SIZES (mm)				Applicable Tap	
	D	L1	L2	D2	Size	Limit
NDPG503 010	1	5	38	3	-	-
NDPG503 011	1,1	6	42	3	-	-
NDPG503 012	1,2	6	42	3	-	-
NDPG503 013	1,3	6	42	3	-	-
NDPG503 014	1,4	7	42	3	-	-
NDPG503 015	1,5	7	42	3	-	-
NDPG503 016	1,6	8	42	3	-	-
NDPG503 017	1,7	8	42	3	-	-
NDPG503 018	1,8	9	42	3	-	-
NDPG503 019	1,9	9	42	3	-	-
NDPG503 020	2	10	50	3	-	-
NDPG503 021	2,1	10	50	3	-	-
NDPG503 022	2,2	11	50	3	-	-
NDPG503 023	2,3	11	50	3	-	-
NDPG503 024	2,4	12	50	3	-	-
NDPG503 025	2,5	12	50	3	M3x0,5	WH1~4
NDPG503 026	2,6	12	50	3	M3x0,5	WH5~6
NDPG503 027	2,7	14	50	3	-	-
NDPG503 028	2,8	14	50	3	-	-
NDPG503 029	2,9	14	50	3	-	-
NDPG503 030	3	14	55	3	-	-
NDPG503 031	3,1	16	55	4	-	-
NDPG503 03175	3,175	16	55	4	-	-
NDPG503 032	3,2	16	55	4	-	-
NDPG503 03264	3,264	16	55	4	-	-
NDPG503 033	3,3	16	55	4	M4x0,7	WH1~4
NDPG503 034	3,4	16	55	4	M4x0,7	WH5~6
NDPG503 035	3,5	16	55	4	-	-
NDPG503 03572	3,572	18	55	4	-	-
NDPG503 036	3,6	18	55	4	-	-
NDPG503 037	3,7	18	55	4	-	-

EDP No	SIZES (mm)				Applicable Tap	
	D	L1	L2	D2	Size	Limit
NDPG503 038	3,8	20	55	4	-	-
NDPG503 039	3,9	20	55	4	-	-
NDPG503 040	4	20	55	4	-	-
NDPG503 04039	4,039	20	55	5	-	-
NDPG503 041	4,1	20	55	5	-	-
NDPG503 042	4,2	20	62	5	M5x0,8	WH1~4
NDPG503 043	4,3	22	62	5	M5x0,8	WH5~6
NDPG503 044	4,4	22	62	5	-	-
NDPG503 045	4,5	22	62	5	-	-
NDPG503 046	4,6	22	62	5	-	-
NDPG503 047	4,7	22	62	5	-	-
NDPG503 04763	4,763	24	62	5	-	-
NDPG503 048	4,8	24	62	5	-	-
NDPG503 049	4,9	24	62	5	-	-
NDPG503 050	5	24	62	5	M6x1,0	WH1~4
NDPG503 051	5,1	24	62	6	M6x1,0	WH5~6
NDPG503 05159	5,159	28	66	6	-	-
NDPG503 052	5,2	28	66	6	-	-
NDPG503 053	5,3	28	66	6	-	-
NDPG503 054	5,4	28	66	6	-	-
NDPG503 055	5,5	28	66	6	-	-
NDPG503 05556	5,556	28	66	6	-	-
NDPG503 056	5,6	28	66	6	-	-
NDPG503 057	5,7	28	66	6	-	-
NDPG503 058	5,8	28	66	6	-	-
NDPG503 059	5,9	28	66	6	-	-
NDPG503 05953	5,953	28	66	6	-	-
NDPG503 060	6	28	66	6	-	-
NDPG503 061	6,1	30	66	7	-	-
NDPG503 062	6,2	34	74	7	-	-
NDPG503 063	6,3	34	74	7	-	-

Applicable Work Materials

P			H		M	K	N
Carbon Steel ~HB225	Alloy Steel HB225~325	Prehardened Steel HRC30 ~ 50	Hardened Steel		Stainless	Cast Iron	Non-ferrous & Aluminum
			SKD61 ~HRC55	SKD11 HRC55~			
◎	◎	◎	○		◎	○	○

○ : Good ◎ : Excellent

NDPG503

NEW DOLPHIN GENERAL PURPOSE DRILL

EDP No	SIZES (mm)				Applicable Tap	
	D	L1	L2	D2	Size	Limit
NDPG503 0635	6.35	34	74	7	-	-
NDPG503 064	6.4	34	74	7	-	-
NDPG503 065	6.5	34	74	7	-	-
NDPG503 066	6.6	34	74	7	-	-
NDPG503 067	6.7	37	74	7	-	-
NDPG503 06747	6.747	37	74	7	-	-
NDPG503 068	6.8	37	74	7	M8x1,25	WH1~4
NDPG503 069	6.9	37	74	7	M8x1,25	WH5~6
NDPG503 070	7	37	74	7	M8x1,0	WH1~4
NDPG503 071	7.1	37	74	8	M8x1,0	WH5~6
NDPG503 07144	7.144	40	79	8	-	-
NDPG503 072	7.2	40	79	8	-	-
NDPG503 073	7.3	40	79	8	-	-
NDPG503 074	7.4	40	79	8	-	-
NDPG503 075	7.5	40	79	8	-	-
NDPG503 07541	7.541	40	79	8	-	-
NDPG503 076	7.6	40	79	8	-	-
NDPG503 077	7.7	40	79	8	-	-
NDPG503 078	7.8	40	79	8	-	-
NDPG503 079	7.9	40	79	8	-	-
NDPG503 07938	7.938	40	79	8	-	-
NDPG503 080	8	40	79	8	-	-
NDPG503 081	8.1	40	79	9	-	-
NDPG503 082	8.2	43	84	9	-	-
NDPG503 083	8.3	43	84	9	-	-
NDPG503 084	8.4	43	84	9	-	-
NDPG503 085	8.5	43	84	9	M10x1,5	WH1~4
NDPG503 086	8.6	43	84	9	M10x1,5	WH5~6
NDPG503 087	8.7	43	84	9	-	-
NDPG503 08731	8.731	43	84	9	-	-
NDPG503 088	8.8	43	84	9	M10x1,25	WH1~4
NDPG503 089	8.9	43	84	9	M10x1,25	WH5~6
NDPG503 090	9	43	84	9	M10x1,0	WH1~4
NDPG503 091	9.1	43	84	10	M10x1,0	WH5~6
NDPG503 092	9.2	47	89	10	-	-
NDPG503 093	9.3	47	89	10	-	-
NDPG503 094	9.4	47	89	10	-	-
NDPG503 095	9.5	47	89	10	-	-
NDPG503 09525	9.525	47	89	10	-	-

EDP No	SIZES (mm)				Applicable Tap	
	D	L1	L2	D2	Size	Limit
NDPG503 096	9.6	47	89	10	-	-
NDPG503 097	9.7	47	89	10	-	-
NDPG503 098	9.8	47	89	10	-	-
NDPG503 099	9.9	47	89	10	-	-
NDPG503 100	10	47	89	10	-	-
NDPG503 101	10.1	47	89	11	-	-
NDPG503 102	10.2	51	95	11	-	-
NDPG503 103	10.3	51	95	11	M12x1,75	WH1~2
NDPG503 10319	10.319	51	95	11	M12x1,75	WH3~4
NDPG503 104	10.4	51	95	11	M12x1,75	WH5~6
NDPG503 105	10.5	51	95	11	M12x1,5	WH1~4
NDPG503 106	10.6	51	95	11	M12x1,5	WH5~6
NDPG503 107	10.7	51	95	11	-	-
NDPG503 10716	10.716	51	95	11	-	-
NDPG503 108	10.8	51	95	11	M12x1,25	WH1~4
NDPG503 109	10.9	51	95	11	M12x1,25	WH5~6
NDPG503 110	11	51	95	11	M12x1,0	WH1~4
NDPG503 111	11.1	51	95	12	M12x1,0	WH5~6
NDPG503 11113	11.113	54	102	12	-	-
NDPG503 112	11.2	54	102	12	-	-
NDPG503 113	11.3	54	102	12	-	-
NDPG503 114	11.4	54	102	12	-	-
NDPG503 115	11.5	54	102	12	-	-
NDPG503 116	11.6	54	102	12	-	-
NDPG503 117	11.7	54	102	12	-	-
NDPG503 118	11.8	54	102	12	-	-
NDPG503 119	11.9	54	102	12	-	-
NDPG503 120	12	54	102	12	M14x2,0	WH1~4
NDPG503 121	12.1	54	102	13	M14x2,0	WH5~6
NDPG503 122	12.2	57	102	13	-	-
NDPG503 123	12.3	57	102	13	-	-
NDPG503 124	12.4	57	102	13	-	-
NDPG503 125	12.5	57	102	13	M14x1,5	WH1~4
NDPG503 126	12.6	57	102	13	M14x1,5	WH5~6
NDPG503 127	12.7	57	102	13	-	-
NDPG503 128	12.8	57	102	13	-	-
NDPG503 129	12.9	57	102	13	-	-
NDPG503 130	13	57	102	13	-	-

■ Applicable Work Materials

P			H		M	K	N
Carbon Steel ~HB225	Alloy Steel HB225~325	Prehardened Steel HRC30 ~ 50	Hardened Steel		Stainless	Cast Iron	Non-ferrous & Aluminum
			SKD61 ~HRC55	SKD11 HRC55~			
◎	◎	◎	○		◎	○	○

○ : Good ◎ : Excellent

NDPG504

NEW DOLPHIN GENERAL PURPOSE DRILL

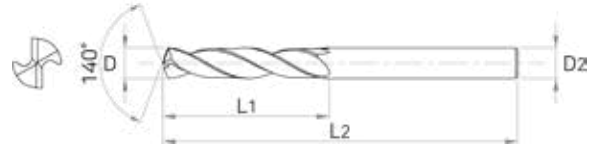
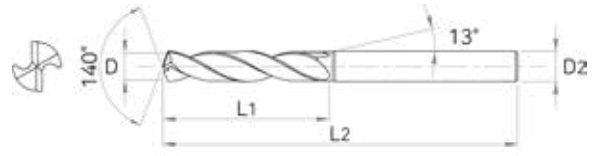

Tolerance

Cutting Dia (mm)		Shank Dia h6
D1 ~ D3	0 ~ -0,010	
D3,1 ~ D6	0 ~ -0,012	
D6,1 ~ D10	0 ~ -0,015	
D10,1 ~ D18	0 ~ -0,018	
D18,1 ~	0 ~ -0,021	

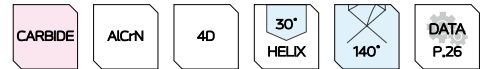

EDP No	SIZES (mm)				Applicable Tap	
	D	L1	L2	D2	Size	Limit
NDPG504 010	1	8	38	3	-	-
NDPG504 011	1,1	9	42	3	-	-
NDPG504 012	1,2	10	42	3	-	-
NDPG504 013	1,3	10	42	3	-	-
NDPG504 014	1,4	11	42	3	-	-
NDPG504 015	1,5	11	42	3	-	-
NDPG504 016	1,6	12	42	3	-	-
NDPG504 017	1,7	12	42	3	-	-
NDPG504 018	1,8	13	42	3	-	-
NDPG504 019	1,9	13	42	3	-	-
NDPG504 020	2	18	50	3	-	-
NDPG504 021	2,1	18	50	3	-	-
NDPG504 022	2,2	18	50	3	-	-
NDPG504 023	2,3	18	50	3	-	-
NDPG504 024	2,4	18	50	3	-	-
NDPG504 025	2,5	18	50	3	M3x0,5	WH1~4
NDPG504 026	2,6	18	50	3	M3x0,5	WH5~6
NDPG504 027	2,7	18	50	3	-	-
NDPG504 028	2,8	18	50	3	-	-
NDPG504 029	2,9	18	50	3	-	-
NDPG504 030	3	20	55	3	-	-
NDPG504 031	3,1	20	55	4	-	-
NDPG504 03175	3,175	20	55	4	-	-
NDPG504 032	3,2	20	55	4	-	-
NDPG504 03264	3,264	20	55	4	-	-
NDPG504 033	3,3	20	55	4	M4x0,7	WH1~4
NDPG504 034	3,4	20	55	4	M4x0,7	WH 5~6
NDPG504 035	3,5	20	55	4	-	-
NDPG504 03572	3,572	25	55	4	-	-
NDPG504 036	3,6	25	55	4	-	-
NDPG504 037	3,7	25	55	4	-	-

EDP No	SIZES (mm)				Applicable Tap	
	D	L1	L2	D2	Size	Limit
NDPG504 038	3,8	25	55	4	-	-
NDPG504 039	3,9	25	55	4	-	-
NDPG504 040	4	25	55	4	-	-
NDPG504 04039	4,039	25	55	5	-	-
NDPG504 041	4,1	25	55	5	-	-
NDPG504 042	4,2	33	63	5	M5x0,8	WH1~4
NDPG504 043	4,3	33	63	5	M5x0,8	WH5~6
NDPG504 044	4,4	33	63	5	-	-
NDPG504 045	4,5	33	63	5	-	-
NDPG504 046	4,6	33	63	5	-	-
NDPG504 047	4,7	33	63	5	-	-
NDPG504 04763	4,763	33	63	5	-	-
NDPG504 048	4,8	33	63	5	-	-
NDPG504 049	4,9	33	63	5	-	-
NDPG504 050	5	33	63	5	M6x1,0	WH1~4
NDPG504 051	5,1	33	63	6	M6x1,0	WH5~6
NDPG504 05159	5,159	36	66	6	-	-
NDPG504 052	5,2	36	66	6	-	-
NDPG504 053	5,3	36	66	6	-	-
NDPG504 054	5,4	36	66	6	-	-
NDPG504 055	5,5	36	66	6	-	-
NDPG504 05556	5,556	36	66	6	-	-
NDPG504 056	5,6	36	66	6	-	-
NDPG504 057	5,7	36	66	6	-	-
NDPG504 058	5,8	36	66	6	-	-
NDPG504 059	5,9	36	66	6	-	-
NDPG504 05953	5,953	36	66	6	-	-
NDPG504 060	6	36	66	6	-	-
NDPG504 061	6,1	36	66	7	-	-
NDPG504 062	6,2	42	75	7	-	-
NDPG504 063	6,3	42	75	7	-	-

Applicable Work Materials

P			H		M	K	N
Carbon Steel ~HB225	Alloy Steel HB225~325	Prehardened Steel HRC30 ~ 50	Hardened Steel		Stainless	Cast Iron	Non-ferrous & Aluminum
			SKD61 ~HRC55	SKD11 HRC55~			
◎	◎	◎	○		◎	○	○

○ : Good ◎ : Excellent

NDPG504

NEW DOLPHIN GENERAL PURPOSE DRILL

EDP No	SIZES (mm)				Applicable Tap	
	D	L1	L2	D2	Size	Limit
NDPG504 0635	6.35	42	75	7	-	-
NDPG504 064	6.4	42	75	7	-	-
NDPG504 065	6.5	42	75	7	-	-
NDPG504 066	6.6	42	75	7	-	-
NDPG504 067	6.7	42	75	7	-	-
NDPG504 06747	6.747	42	75	7	-	-
NDPG504 068	6.8	42	75	7	M8x1.25	WH1~4
NDPG504 069	6.9	42	75	7	M8x1.25	WH5~6
NDPG504 070	7	42	75	7	M8x1.0	WH1~4
NDPG504 071	7.1	42	75	8	M8x1.0	WH5~6
NDPG504 07144	7.144	46	80	8	-	-
NDPG504 072	7.2	46	80	8	-	-
NDPG504 073	7.3	46	80	8	-	-
NDPG504 074	7.4	46	80	8	-	-
NDPG504 075	7.5	46	80	8	-	-
NDPG504 07541	7.541	46	80	8	-	-
NDPG504 076	7.6	46	80	8	-	-
NDPG504 077	7.7	46	80	8	-	-
NDPG504 078	7.8	46	80	8	-	-
NDPG504 079	7.9	46	80	8	-	-
NDPG504 07938	7.938	46	80	8	-	-
NDPG504 080	8	46	80	8	-	-
NDPG504 081	8.1	46	80	9	-	-
NDPG504 082	8.2	50	85	9	-	-
NDPG504 083	8.3	50	85	9	-	-
NDPG504 084	8.4	50	85	9	-	-
NDPG504 085	8.5	50	85	9	M10x1.5	WH1~4
NDPG504 086	8.6	50	85	9	M10x1.5	WH5~6
NDPG504 087	8.7	50	85	9	-	-
NDPG504 08731	8.731	50	85	9	-	-
NDPG504 088	8.8	50	85	9	M10x1.25	WH1~4
NDPG504 089	8.9	50	85	9	M10x1.25	WH5~6
NDPG504 090	9	50	85	9	M10x1.0	WH1~4
NDPG504 091	9.1	50	85	10	M10x1.0	WH5~6
NDPG504 092	9.2	55	90	10	-	-
NDPG504 093	9.3	55	90	10	-	-
NDPG504 095	9.5	55	90	10	-	-
NDPG504 095	9.5	55	90	10	-	-
NDPG504 09525	9.525	55	90	10	-	-
NDPG504 09525	9.525	55	90	10	-	-
NDPG504 096	9.6	55	90	10	-	-
NDPG504 097	9.7	55	90	10	-	-
NDPG504 098	9.8	55	90	10	-	-
NDPG504 099	9.9	55	90	10	-	-
NDPG504 100	10	55	90	10	-	-
NDPG504 101	10.1	55	90	11	-	-
NDPG504 102	10.2	57	95	11	-	-
NDPG504 103	10.3	57	95	11	M12x1.75	WH1~2
NDPG504 10319	10.319	57	95	11	M12x1.75	WH3~4

EDP No	SIZES (mm)				Applicable Tap	
	D	L1	L2	D2	Size	Limit
NDPG504 104	10.4	57	95	11	M12x1.75	WH5~6
NDPG504 105	10.5	57	95	11	M12x1.5	WH1~4
NDPG504 106	10.6	57	95	11	M12x1.5	WH5~6
NDPG504 107	10.7	57	95	11	-	-
NDPG504 10716	10.716	57	95	11	-	-
NDPG504 108	10.8	57	95	11	M12x1.25	WH1~4
NDPG504 109	10.9	57	95	11	M12x1.25	WH5~6
NDPG504 110	11	57	95	11	M12x1.0	WH1~4
NDPG504 111	11.1	57	95	12	M12x1.0	WH5~6
NDPG504 11113	11.113	63	102	12	-	-
NDPG504 112	11.2	63	102	12	-	-
NDPG504 113	11.3	63	102	12	-	-
NDPG504 114	11.4	63	102	12	-	-
NDPG504 115	11.5	63	102	12	-	-
NDPG504 116	11.6	63	102	12	-	-
NDPG504 117	11.7	63	102	12	-	-
NDPG504 118	11.8	63	102	12	-	-
NDPG504 119	11.9	63	102	12	-	-
NDPG504 120	12	63	102	12	M14x2.0	WH1~4
NDPG504 121	12.1	63	102	13	M14x2.0	WH5~6
NDPG504 122	12.2	63	102	13	-	-
NDPG504 123	12.3	63	102	13	-	-
NDPG504 124	12.4	63	102	13	-	-
NDPG504 125	12.5	63	102	13	M14x1.5	WH1~4
NDPG504 126	12.6	63	102	13	M14x1.5	WH5~6
NDPG504 127	12.7	63	102	13	-	-
NDPG504 128	12.8	63	102	13	-	-
NDPG504 129	12.9	63	102	13	-	-
NDPG504 130	13	63	102	13	-	-
NDPG504 131	13.1	63	102	14	-	-
NDPG504 132	13.2	65	107	14	-	-
NDPG504 133	13.3	65	107	14	-	-
NDPG504 134	13.4	65	107	14	-	-
NDPG504 13494	13.494	65	107	14	-	-
NDPG504 135	13.5	65	107	14	-	-
NDPG504 136	13.6	65	107	14	-	-
NDPG504 137	13.7	65	107	14	-	-
NDPG504 138	13.8	65	107	14	-	-
NDPG504 139	13.9	65	107	14	-	-
NDPG504 140	14	65	107	14	M16x2.0	WH1~4
NDPG504 141	14.1	65	107	15	M16x2.0	WH5~6
NDPG504 142	14.2	67	111	15	-	-
NDPG504 143	14.3	67	111	15	-	-
NDPG504 144	14.4	67	111	15	-	-
NDPG504 145	14.5	67	111	15	M16x1.5	WH1~4
NDPG504 146	14.6	67	111	15	M16x1.5	WH5~6
NDPG504 147	14.7	67	111	15	-	-
NDPG504 148	14.8	67	111	15	-	-
NDPG504 149	14.9	67	111	15	-	-

■ Applicable Work Materials

P			H		M	K	N
Carbon Steel ~HB225	Alloy Steel HB225~325	Prehardened Steel HRC30 ~ 50	Hardened Steel		Stainless	Cast Iron	Non-ferrous & Aluminum
			SKD61 ~HRC55	SKD11 HRC55~			
◎	◎	◎	○		◎	○	○

○ : Good ◎ : Excellent

EDP No	SIZES (mm)				Applicable Tap	
	D	L1	L2	D2	Size	Limit
NDPG504 150	15	67	111	15	-	-
NDPG504 151	15,1	67	111	16	-	-
NDPG504 152	15,2	69	115	16	-	-
NDPG504 154	15,4	69	115	16	-	-
NDPG504 155	15,5	69	115	16	M18x2,5	WH1~4
NDPG504 156	15,6	69	115	16	M18x2,5	WH5~6
NDPG504 157	15,7	69	115	16	-	-
NDPG504 158	15,8	69	115	16	-	-
NDPG504 15875	15,875	69	115	16	-	-
NDPG504 160	16	69	115	16	-	-
NDPG504 161	16,1	69	115	17	-	-
NDPG504 163	16,3	71	119	17	-	-
NDPG504 165	16,5	71	119	17	M18x1,5	WH1~6
NDPG504 16669	16,669	71	119	17	-	-
NDPG504 170	17	71	119	17	-	-

EDP No	SIZES (mm)				Applicable Tap	
	D	L1	L2	D2	Size	Limit
NDPG504 171	17,1	71	119	18	-	-
NDPG504 172	17,2	74	123	18	-	-
NDPG504 175	17,5	74	123	18	M20x2,5	WH1~6
NDPG504 177	17,7	74	123	18	-	-
NDPG504 178	17,8	74	123	18	-	-
NDPG504 180	18	74	123	18	-	-
NDPG504 181	18,1	74	123	19	-	-
NDPG504 182	18,2	76	127	19	-	-
NDPG504 185	18,5	76	127	19	M20x1,5	WH1~6
NDPG504 190	19	76	127	19	-	-
NDPG504 191	19,1	76	127	20	-	-
NDPG504 195	19,5	80	131	20	M22x2,5	WH1~6
NDPG504 197	19,7	80	131	20	-	-
NDPG504 200	20	80	131	20	-	-

■ Applicable Work Materials

P			H		M	K	N
Carbon Steel ~HB225	Alloy Steel HB225~325	Prehardened Steel HRC30 ~ 50	Hardened Steel		Stainless	Cast Iron	Non-ferrous & Aluminum
			SKD61 ~HRC55	SKD11 HRC55~			
◎	◎	◎	○		◎	○	○

○ : Good ◎ : Excellent

NDPG507

NEW DOLPHIN GENERAL PURPOSE DRILL

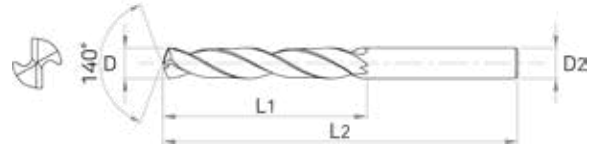
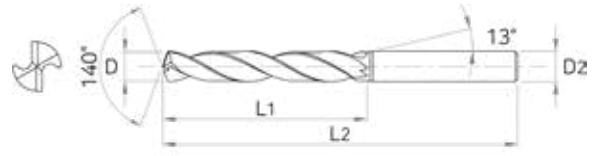

Tolerance

Cutting Dia (mm)		Shank Dia h6
D1 ~ D3	0 ~ -0.010	
D3.1 ~ D6	0 ~ -0.012	
D6.1 ~ D10	0 ~ -0.015	
D10.1 ~ D18	0 ~ -0.018	
D18.1 ~	0 ~ -0.021	

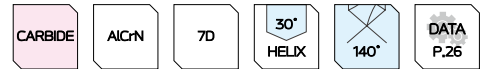

EDP No	SIZES (mm)				Applicable Tap	
	D	L1	L2	D2	Size	Limit
NDPG507 030	3	45	80	3	-	-
NDPG507 031	3.1	45	80	4	-	-
NDPG507 03175	3.175	45	80	4	-	-
NDPG507 032	3.2	45	80	4	-	-
NDPG507 03264	3.264	45	80	4	-	-
NDPG507 033	3.3	45	80	4	M4x0.7	WH1~4
NDPG507 034	3.4	45	80	4	M4x0.7	WH5~6
NDPG507 035	3.5	45	80	4	-	-
NDPG507 03572	3.572	45	80	4	-	-
NDPG507 036	3.6	45	80	4	-	-
NDPG507 037	3.7	45	80	4	-	-
NDPG507 038	3.8	45	80	4	-	-
NDPG507 039	3.9	45	80	4	-	-
NDPG507 040	4	45	80	4	-	-
NDPG507 041	4.1	45	80	5	-	-
NDPG507 042	4.2	45	80	5	M5x0.8	WH1~4
NDPG507 043	4.3	45	80	5	M5x0.8	WH5~6
NDPG507 044	4.4	45	80	5	-	-
NDPG507 045	4.5	45	80	5	-	-
NDPG507 046	4.6	45	80	5	-	-
NDPG507 047	4.7	45	80	5	-	-
NDPG507 04763	4.763	45	80	5	-	-
NDPG507 048	4.8	45	80	5	-	-
NDPG507 049	4.9	45	80	5	-	-
NDPG507 050	5	45	80	5	M6x1.0	WH1~4
NDPG507 051	5.1	45	80	6	M6x1.0	WH5~6
NDPG507 05159	5.159	50	83	6	-	-
NDPG507 052	5.2	50	83	6	-	-
NDPG507 053	5.3	50	83	6	-	-
NDPG507 054	5.4	50	83	6	-	-
NDPG507 055	5.5	50	83	6	-	-
NDPG507 05556	5.556	50	83	6	-	-

EDP No	SIZES (mm)				Applicable Tap	
	D	L1	L2	D2	Size	Limit
NDPG507 056	5.6	50	83	6	-	-
NDPG507 057	5.7	50	83	6	-	-
NDPG507 058	5.8	50	83	6	-	-
NDPG507 059	5.9	50	83	6	-	-
NDPG507 060	6	50	83	6	-	-
NDPG507 061	6.1	50	83	7	-	-
NDPG507 062	6.2	53	85	7	-	-
NDPG507 063	6.3	53	85	7	-	-
NDPG507 06355	6.355	53	85	7	-	-
NDPG507 064	6.4	53	85	7	-	-
NDPG507 065	6.5	53	85	7	-	-
NDPG507 066	6.6	53	85	7	-	-
NDPG507 067	6.7	53	85	7	-	-
NDPG507 06747	6.747	53	85	7	-	-
NDPG507 068	6.8	53	85	7	M8x1.25	WH1~4
NDPG507 069	6.9	53	85	7	M8x1.25	WH5~6
NDPG507 070	7	53	85	7	M8x1.0	WH1~4
NDPG507 071	7.1	53	85	8	M8x1.0	WH5~6
NDPG507 07144	7.144	58	90	8	-	-
NDPG507 072	7.2	58	90	8	-	-
NDPG507 073	7.3	58	90	8	-	-
NDPG507 074	7.4	58	90	8	-	-
NDPG507 075	7.5	58	90	8	-	-
NDPG507 076	7.6	58	90	8	-	-
NDPG507 077	7.7	58	90	8	-	-
NDPG507 078	7.8	58	90	8	-	-
NDPG507 079	7.9	58	90	8	-	-
NDPG507 07938	7.938	58	90	8	-	-
NDPG507 080	8	58	90	8	-	-
NDPG507 081	8.1	58	90	9	-	-
NDPG507 082	8.2	64	98	9	-	-
NDPG507 083	8.3	64	98	9	-	-

Applicable Work Materials

P			H		M	K	N
Carbon Steel ~HB225	Alloy Steel HB225~325	Prehardened Steel HRC30 ~ 50	Hardened Steel		Stainless	Cast Iron	Non-ferrous & Aluminum
			SKD61 ~HRC55	SKD11 HRC55~			
◎	◎	◎	○		◎	○	○

○ : Good ◎ : Excellent

NDPG507

NEW DOLPHIN GENERAL PURPOSE DRILL

EDP No	SIZES (mm)				Applicable Tap	
	D	L1	L2	D2	Size	Limit
NDPG507 084	8,4	64	98	9	-	-
NDPG507 085	8,5	64	98	9	M10x1,5	WH1~4
NDPG507 086	8,6	64	98	9	M10x1,5	WH5~6
NDPG507 087	8,7	64	98	9	-	-
NDPG507 08731	8,731	64	98	9	-	-
NDPG507 088	8,8	64	98	9	M10x1,25	WH1~4
NDPG507 089	8,9	64	98	9	M10x1,25	WH5~6
NDPG507 090	9	64	98	9	M10x1,0	WH1~4
NDPG507 091	9,1	64	98	10	M10x1,0	WH5~6
NDPG507 092	9,2	68	105	10	-	-
NDPG507 093	9,3	68	105	10	-	-
NDPG507 094	9,4	68	105	10	-	-
NDPG507 095	9,5	68	105	10	-	-
NDPG507 09525	9,525	68	105	10	-	-
NDPG507 096	9,6	68	105	10	-	-
NDPG507 097	9,7	68	105	10	-	-
NDPG507 098	9,8	68	105	10	-	-
NDPG507 099	9,9	68	105	10	-	-
NDPG507 100	10	68	105	10	-	-
NDPG507 101	10,1	68	105	11	-	-
NDPG507 102	10,2	73	110	11	-	-
NDPG507 103	10,3	73	110	11	M12x1,75	WH1~2
NDPG507 10319	10,319	73	110	11	M12x1,75	WH3~4
NDPG507 104	10,4	73	110	11	M12x1,75	WH5~6
NDPG507 105	10,5	73	110	11	M12x1,5	WH1~4
NDPG507 106	10,6	73	110	11	M12x1,5	WH5~6
NDPG507 107	10,7	73	110	11	-	-
NDPG507 10716	10,716	73	110	11	-	-
NDPG507 108	10,8	73	110	11	M12x1,25	WH1~4
NDPG507 109	10,9	73	110	11	M12x1,25	WH5~6
NDPG507 110	11	73	110	11	M12x1,0	WH1~4
NDPG507 111	11,1	73	110	12	M12x1,0	WH5~6
NDPG507 11113	11,113	80	120	12	-	-
NDPG507 112	11,2	80	120	12	-	-
NDPG507 113	11,3	80	120	12	-	-
NDPG507 114	11,4	80	120	12	-	-
NDPG507 115	11,5	80	120	12	-	-
NDPG507 116	11,6	80	120	12	-	-
NDPG507 117	11,7	80	120	12	-	-
NDPG507 118	11,8	80	120	12	-	-
NDPG507 119	11,9	80	120	12	-	-
NDPG507 120	12	80	120	12	M14x2,0	WH1~4
NDPG507 121	12,1	80	120	13	M14x2,0	WH5~6
NDPG507 122	12,2	90	137	13	-	-
NDPG507 123	12,3	90	137	13	-	-
NDPG507 124	12,4	90	137	13	-	-
NDPG507 125	12,5	90	137	13	M14x1,5	WH1~4
NDPG507 126	12,6	90	137	13	M14x1,5	WH5~6
NDPG507 127	12,7	90	137	13	-	-
NDPG507 128	12,8	90	137	13	-	-

EDP No	SIZES (mm)				Applicable Tap	
	D	L1	L2	D2	Size	Limit
NDPG507 129	12,9	90	137	13	-	-
NDPG507 130	13	90	137	13	-	-
NDPG507 131	13,1	90	137	14	-	-
NDPG507 133	13,3	96	147	14	-	-
NDPG507 134	13,4	96	147	14	-	-
NDPG507 13494	13,494	96	147	14	-	-
NDPG507 135	13,5	96	147	14	-	-
NDPG507 136	13,6	96	147	14	-	-
NDPG507 137	13,7	96	147	14	-	-
NDPG507 138	13,8	96	147	14	-	-
NDPG507 13891	13,891	96	147	14	-	-
NDPG507 139	13,9	96	147	14	-	-
NDPG507 140	14	96	147	14	M16x2,0	WH1~4
NDPG507 141	14,1	96	147	15	M16x2,0	WH5~6
NDPG507 142	14,2	100	153	15	-	-
NDPG507 14288	14,288	100	153	15	-	-
NDPG507 143	14,3	100	153	15	-	-
NDPG507 145	14,5	100	153	15	M16x1,5	WH1~4
NDPG507 146	14,6	100	153	15	M16x1,5	WH5~6
NDPG507 147	14,7	100	153	15	-	-
NDPG507 148	14,8	100	153	15	-	-
NDPG507 149	14,9	100	153	15	-	-
NDPG507 150	15	100	153	15	-	-
NDPG507 151	15,1	100	153	16	-	-
NDPG507 154	15,4	112	160	16	-	-
NDPG507 155	15,5	112	160	16	M18x2,5	WH1~4
NDPG507 156	15,6	112	160	16	M18x2,5	WH5~6
NDPG507 157	15,7	112	160	16	-	-
NDPG507 158	15,8	112	160	16	-	-
NDPG507 15875	15,875	112	160	16	-	-
NDPG507 160	16	112	160	16	-	-
NDPG507 161	16,1	112	160	17	-	-
NDPG507 163	16,3	112	160	17	-	-
NDPG507 165	16,5	112	160	17	M18x1,5	WH1~6
NDPG507 16669	16,669	112	160	17	-	-
NDPG507 170	17	112	160	17	-	-
NDPG507 171	17,1	112	160	18	-	-
NDPG507 172	17,2	112	160	18	-	-
NDPG507 17463	17,463	112	160	18	-	-
NDPG507 175	17,5	112	160	18	M20x2,5	WH1~6
NDPG507 177	17,7	112	160	18	-	-
NDPG507 178	17,8	112	160	18	-	-
NDPG507 180	18	112	160	18	-	-
NDPG507 182	18,2	112	160	19	-	-
NDPG507 185	18,5	112	160	19	M20x1,5	WH1~6
NDPG507 190	19	112	160	19	-	-
NDPG507 195	19,5	112	160	20	M22x2,5	WH1~6
NDPG507 197	19,7	112	160	20	-	-
NDPG507 200	20	112	160	20	-	-

■ Applicable Work Materials

P			H		M	K	N
Carbon Steel ~HB225	Alloy Steel HB225~325	Prehardened Steel HRC30 ~ 50	Hardened Steel		Stainless	Cast Iron	Non-ferrous & Aluminum
			SKD61 ~HRC55	SKD11 HRC55~			
◎	◎	◎	○		◎	○	○



○ : Good ◎ : Excellent



02. NDPGH SERIES



◆ : Metric ◇ : Inch

EDP No	Standard	Flute	Geometry	Length			Coolant	Margin	Tolerance	Cutting Dia (mm)		Page
				3D	5D	8D				Min	Max	
NDPGH503	◆◇	2 Flute		○			Internal	Single	m7	3	20	17
NDPGH505	◆◇				○		Internal	Single	m7	3	20	20
NDPGH508	◆◇					○	Internal	Single	m7	3	16	23
Recommended Cutting Condition											26	

NDPGH503

NEW DOLPHIN GENERAL OIL HOLE DRILL

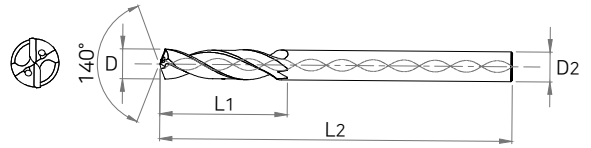
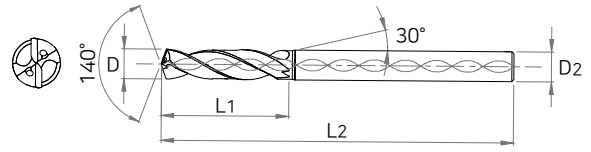

Tolerance

Cutting Dia (mm)		Shank Dia
~ D3	+0.002~+0.012	
D3.1~D6	+0.004~+0.016	
D6.1~D10	+0.006~+0.021	
D10.1~D18	+0.007~+0.025	
D18.1~D20	+0.008~+0.029	

h6

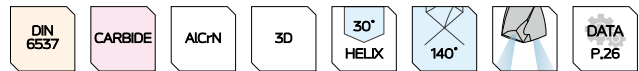

EDP No	SIZES (mm)				Applicable Tap	
	D	L1	L2	D2	Size	Limit
NDPGH503030D	3,0	20	62	6	-	-
NDPGH503031D	3,1	20	62	6	-	-
NDPGH50303175D	3,175	20	62	6	-	-
NDPGH503032D	3,2	20	62	6	-	-
NDPGH503033D	3,3	20	62	6	M4x0,7	WH1~4
NDPGH503034D	3,4	20	62	6	M4x0,7	WH5~6
NDPGH503035D	3,5	20	62	6	-	-
NDPGH50303572D	3,572	20	62	6	-	-
NDPGH503036D	3,6	20	62	6	-	-
NDPGH503037D	3,7	20	62	6	-	-
NDPGH503038D	3,8	24	66	6	-	-
NDPGH503039D	3,9	24	66	6	-	-
NDPGH50303969D	3,969	24	66	6	-	-
NDPGH503040D	4,0	24	66	6	-	-
NDPGH50304039D	4,039	24	66	6	-	-
NDPGH503041D	4,1	24	66	6	-	-
NDPGH503042D	4,2	24	66	6	M5x0,8	WH1~4
NDPGH503043D	4,3	24	66	6	M5x0,8	WH5~6
NDPGH50304366D	4,366	24	66	6	-	-
NDPGH503044D	4,4	24	66	6	-	-
NDPGH503045D	4,5	24	66	6	-	-
NDPGH503046D	4,6	24	66	6	-	-
NDPGH503047D	4,7	24	66	6	-	-
NDPGH50304763D	4,763	28	66	6	-	-
NDPGH503048D	4,8	28	66	6	-	-
NDPGH503049D	4,9	28	66	6	-	-
NDPGH503050D	5,0	28	66	6	M6x1,0	WH1~4
NDPGH503051D	5,1	28	66	6	M6x1,0	WH5~6
NDPGH50305159D	5,159	28	66	6	-	-
NDPGH503052D	5,2	28	66	6	-	-
NDPGH503053D	5,3	28	66	6	-	-

EDP No	SIZES (mm)				Applicable Tap	
	D	L1	L2	D2	Size	Limit
NDPGH503054D	5,4	28	66	6	-	-
NDPGH503055D	5,5	28	66	6	-	-
NDPGH50305556D	5,558	28	66	6	-	-
NDPGH503056D	5,6	28	66	6	-	-
NDPGH503057D	5,7	28	66	6	-	-
NDPGH503058D	5,8	28	66	6	-	-
NDPGH503059D	5,9	28	66	6	-	-
NDPGH50305953D	5,953	28	66	6	-	-
NDPGH503060D	6,0	28	66	6	-	-
NDPGH503061D	6,1	34	79	8	-	-
NDPGH503062D	6,2	34	79	8	-	-
NDPGH503063D	6,3	34	79	8	-	-
NDPGH5030635D	6,35	34	79	8	-	-
NDPGH503064D	6,4	34	79	8	-	-
NDPGH503065D	6,5	34	79	8	-	-
NDPGH50306528D	6,528	34	79	8	-	-
NDPGH503066D	6,6	34	79	8	-	-
NDPGH503067D	6,7	34	79	8	-	-
NDPGH50306747D	6,747	34	79	8	-	-
NDPGH503068D	6,8	34	79	8	M8x1,25	WH1~4
NDPGH503069D	6,9	34	79	8	M8x1,25	WH5~6
NDPGH503070D	7,0	34	79	8	M8x1,0	WH1~4
NDPGH503071D	7,1	41	79	8	M8x1,0	WH5~6
NDPGH50307144D	7,144	41	79	8	-	-
NDPGH503072D	7,2	41	79	8	-	-
NDPGH503073D	7,3	41	79	8	-	-
NDPGH503074D	7,4	41	79	8	-	-
NDPGH503075D	7,5	41	79	8	-	-
NDPGH50307541D	7,541	41	79	8	-	-
NDPGH503076D	7,6	41	79	8	-	-
NDPGH503077D	7,7	41	79	8	-	-

Applicable Work Materials

P			H		M	K	N
Carbon Steel ~HB225	Alloy Steel HB225~325	Prehardened Steel HRC30 ~ 50	Hardened Steel		Stainless	Cast Iron	Non-ferrous & Aluminum
			SKD61 ~HRC55	SKD11 HRC55~			
◎	◎	◎	○		◎	◎	○

○ : Good ◎ : Excellent

NDPGH503

NEW DOLPHIN GENERAL OIL HOLE DRILL

EDP No	SIZES (mm)				Applicable Tap		EDP No	SIZES (mm)				Applicable Tap	
	D	L1	L2	D2	Size	Limit		D	L1	L2	D2	Size	Limit
NDPGH503078D	7,8	41	79	8	-	-	NDPGH50311509D	11,509	55	102	12	-	-
NDPGH503079D	7,9	41	79	8	-	-	NDPGH503116D	11,6	55	102	12	-	-
NDPGH50307938D	7,938	41	79	8	-	-	NDPGH503117D	11,7	55	102	12	-	-
NDPGH503080D	8,0	41	79	8	-	-	NDPGH503118D	11,8	55	102	12	-	-
NDPGH503081D	8,1	47	89	10	-	-	NDPGH503119D	11,9	55	102	12	-	-
NDPGH503082D	8,2	47	89	10	-	-	NDPGH50311906D	11,906	55	102	12	-	-
NDPGH503083D	8,3	47	89	10	-	-	NDPGH503120D	12,0	55	102	12	M14x2,0	WH1~4
NDPGH50308334D	8,334	47	89	10	-	-	NDPGH503121D	12,1	60	107	14	M14x2,0	WH5~6
NDPGH503084D	8,4	47	89	10	-	-	NDPGH503122D	12,2	60	107	14	-	-
NDPGH50308433D	8,433	47	89	10	-	-	NDPGH503123D	12,3	60	107	14	-	-
NDPGH503085D	8,5	47	89	10	M10x1,5	WH1~4	NDPGH50312303D	12,303	60	107	14	-	-
NDPGH503086D	8,6	47	89	10	M10x1,5	WH5~6	NDPGH503124D	12,4	60	107	14	-	-
NDPGH503087D	8,7	47	89	10	-	-	NDPGH503125D	12,5	60	107	14	M14x1,5	WH1~4
NDPGH50308731D	8,731	47	89	10	-	-	NDPGH503126D	12,6	60	107	14	M14x1,5	WH5~6
NDPGH503088D	8,8	47	89	10	M10x1,25	WH1~4	NDPGH503127D	12,7	60	107	14	-	-
NDPGH503089D	8,9	47	89	10	M10x1,25	WH5~6	NDPGH503128D	12,8	60	107	14	-	-
NDPGH503090D	9,0	47	89	10	M10x1,0	WH1~4	NDPGH503129D	12,9	60	107	14	-	-
NDPGH503091D	9,1	47	89	10	M10x1,0	WH5~6	NDPGH503130D	13,0	60	107	14	-	-
NDPGH50309128D	9,128	47	89	10	-	-	NDPGH503131D	13,1	60	107	14	-	-
NDPGH503092D	9,2	47	89	10	-	-	NDPGH503132D	13,2	60	107	14	-	-
NDPGH503093D	9,3	47	89	10	-	-	NDPGH503133D	13,3	60	107	14	-	-
NDPGH50309347D	9,347	47	89	10	-	-	NDPGH503134D	13,4	60	107	14	-	-
NDPGH503094D	9,4	47	89	10	-	-	NDPGH503135D	13,5	60	107	14	-	-
NDPGH503095D	9,5	47	89	10	-	-	NDPGH503136D	13,6	60	107	14	-	-
NDPGH50309525D	9,525	47	89	10	-	-	NDPGH503137D	13,7	60	107	14	-	-
NDPGH503096D	9,6	47	89	10	-	-	NDPGH503138D	13,8	60	107	14	-	-
NDPGH503097D	9,7	47	89	10	-	-	NDPGH50313891D	13,891	60	107	14	-	-
NDPGH503098D	9,8	47	89	10	-	-	NDPGH503139D	13,9	60	107	14	-	-
NDPGH503099D	9,9	47	89	10	-	-	NDPGH503140D	14,0	60	107	14	M16x20	WH1~4
NDPGH50309922D	9,922	47	89	10	-	-	NDPGH503141D	14,1	65	115	16	M16x20	WH5~6
NDPGH503100D	10,0	47	89	10	-	-	NDPGH503142D	14,2	65	115	16	-	-
NDPGH503101D	10,1	55	102	12	-	-	NDPGH50314288D	14,288	65	115	16	-	-
NDPGH503102D	10,2	55	102	12	-	-	NDPGH503143D	14,3	65	115	16	-	-
NDPGH503103D	10,3	55	102	12	M12x1,75	WH1~2	NDPGH503144D	14,4	65	115	16	-	-
NDPGH50310319D	10,319	55	102	12	M12x1,75	WH3~4	NDPGH503145D	14,5	65	115	16	M16x1,5	WH1~4
NDPGH503104D	10,4	55	102	12	M12x1,75	WH5~6	NDPGH503146D	14,6	65	115	16	M16x1,5	WH5~6
NDPGH503105D	10,5	55	102	12	M12x1,5	WH1~4	NDPGH50314684D	14,684	65	115	16	-	-
NDPGH503106D	10,6	55	102	12	M12x1,5	WH5~6	NDPGH503147D	14,7	65	115	16	-	-
NDPGH503107D	10,7	55	102	12	-	-	NDPGH503148D	14,8	65	115	16	-	-
NDPGH50310716D	10,716	55	102	12	-	-	NDPGH503149D	14,9	65	115	16	-	-
NDPGH503108D	10,8	55	102	12	M12x1,25	WH1~4	NDPGH503150D	15,0	65	115	16	-	-
NDPGH503109D	10,9	55	102	12	M12x1,25	WH5~6	NDPGH50315081D	15,081	65	115	16	-	-
NDPGH503110D	11,0	55	102	12	M12x1,0	WH1~4	NDPGH503151D	15,1	65	115	16	-	-
NDPGH503111D	11,1	55	102	12	M12x1,0	WH5~6	NDPGH503152D	15,2	65	115	16	-	-
NDPGH5031113D	11,113	55	102	12	-	-	NDPGH503153D	15,3	65	115	16	-	-
NDPGH503112D	11,2	55	102	12	-	-	NDPGH503154D	15,4	65	115	16	-	-
NDPGH503113D	11,3	55	102	12	-	-	NDPGH50315478D	15,478	65	115	16	-	-
NDPGH503114D	11,4	55	102	12	-	-	NDPGH503155D	15,5	65	115	16	M18x2,5	WH1~4
NDPGH503115D	11,5	55	102	12	-	-	NDPGH503156D	15,6	65	115	16	M18x2,5	WH5~6

■ Applicable Work Materials

P			H		M	K	N
Carbon Steel ~HB225	Alloy Steel HB225~325	Prehardened Steel HRC30 ~ 50	Hardened Steel		Stainless	Cast Iron	Non-ferrous & Aluminum
			SKD61 ~HRC55	SKD11 HRC55~			
◎	◎	◎	○		◎	◎	○

○ : Good ◎ : Excellent

NDPGH503

NEW DOLPHIN GENERAL OIL HOLE DRILL

EDP No	SIZES (mm)				Applicable Tap	
	D	L1	L2	D2	Size	Limit
NDPGH503157D	15,7	65	115	16	-	-
NDPGH503158D	15,8	65	115	16	-	-
NDPGH50315875D	15,875	65	115	16	-	-
NDPGH503159D	15,9	65	115	16	-	-
NDPGH503160D	16,0	65	115	16	-	-
NDPGH50316272D	16,272	73	123	18	-	-
NDPGH503165D	16,5	73	123	18	M18x1,5	WH1~6
NDPGH50316669D	16,669	73	123	18	-	-
NDPGH503170D	17,0	73	123	18	-	-
NDPGH50317066D	17,066	73	123	18	-	-
NDPGH50317463D	17,463	73	123	18	-	-
NDPGH503175D	17,5	73	123	18	M20x2,5	WH1~6

EDP No	SIZES (mm)				Applicable Tap	
	D	L1	L2	D2	Size	Limit
NDPGH50317859D	17,859	73	123	18	-	-
NDPGH503180D	18,0	73	123	18	-	-
NDPGH50318256D	18,256	79	131	20	-	-
NDPGH503185D	18,5	79	131	20	M20x1,5	WH1~6
NDPGH50318654D	18,654	79	131	20	-	-
NDPGH503190D	19,0	79	131	20	-	-
NDPGH5031905D	19,050	79	131	20	-	-
NDPGH5031925D	19,25	79	131	20	-	-
NDPGH50319447D	19,447	79	131	20	-	-
NDPGH503195D	19,5	79	131	20	M22x2,5	WH1~6
NDPGH50319844D	19,844	79	131	20	-	-
NDPGH503200D	20,0	79	131	20	-	-

■ Applicable Work Materials

P			H		M	K	N
Carbon Steel ~HB225	Alloy Steel HB225~325	Prehardened Steel HRC30 ~ 50	Hardened Steel		Stainless	Cast Iron	Non-ferrous & Aluminum
			SKD61 ~HRC55	SKD11 HRC55~			
◎	◎	◎	○		◎	◎	○

○ : Good ◎ : Excellent

NDPGH505

NEW DOLPHIN GENERAL OIL HOLE DRILL

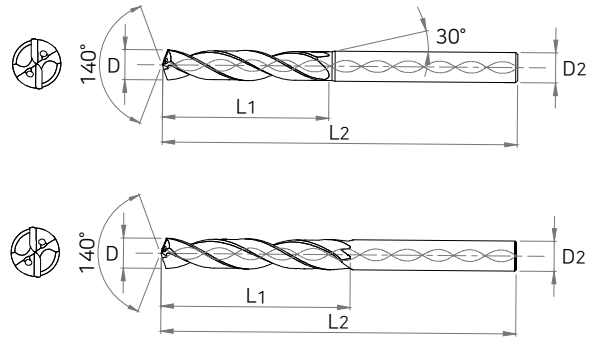

Tolerance

Cutting Dia (mm)		Shank Dia
~ D3	+0.002~+0.012	
D3.1~D6	+0.004~+0.016	
D6.1~D10	+0.006~+0.021	
D10.1~D18	+0.007~+0.025	
D18.1~D20	+0.008~+0.029	

h6

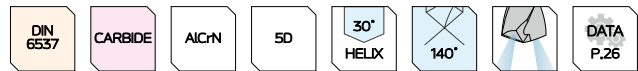

EDP No	SIZES (mm)				Applicable Tap	
	D	L1	L2	D2	Size	Limit
NDPGH505030D	3,0	28	66	6	-	-
NDPGH505031D	3,1	28	66	6	-	-
NDPGH50503175D	3,175	28	66	6	-	-
NDPGH505032D	3,2	28	66	6	-	-
NDPGH505033D	3,3	28	66	6	M4x0,7	WH1~4
NDPGH505034D	3,4	28	66	6	M4x0,7	WH 5~6
NDPGH505035D	3,5	28	66	6	-	-
NDPGH50503572D	3,572	28	66	6	-	-
NDPGH505036D	3,6	28	66	6	-	-
NDPGH505037D	3,7	28	66	6	-	-
NDPGH505038D	3,8	36	74	6	-	-
NDPGH505039D	3,9	36	74	6	-	-
NDPGH50503969D	3,969	36	74	6	-	-
NDPGH505040D	4,0	36	74	6	-	-
NDPGH50504039D	4,039	36	74	6	-	-
NDPGH505041D	4,1	36	74	6	-	-
NDPGH505042D	4,2	36	74	6	M5x0,8	WH1~4
NDPGH505043D	4,3	36	74	6	M5x0,8	WH5~6
NDPGH50504366D	4,366	36	74	6	-	-
NDPGH505044D	4,4	36	74	6	-	-
NDPGH505045D	4,5	36	74	6	-	-
NDPGH505046D	4,6	36	74	6	-	-
NDPGH505047D	4,7	36	74	6	-	-
NDPGH50504763D	4,763	36	74	6	-	-
NDPGH505048D	4,8	44	82	6	-	-
NDPGH505049D	4,9	44	82	6	-	-
NDPGH505050D	5,0	44	82	6	M6x1,0	WH1~4
NDPGH505051D	5,1	44	82	6	M6x1,0	WH5~6
NDPGH50505159D	5,159	44	82	6	-	-
NDPGH505052D	5,2	44	82	6	-	-
NDPGH505053D	5,3	44	82	6	-	-

EDP No	SIZES (mm)				Applicable Tap	
	D	L1	L2	D2	Size	Limit
NDPGH505054D	5,4	44	82	6	-	-
NDPGH505055D	5,5	44	82	6	-	-
NDPGH50505556D	5,558	44	82	6	-	-
NDPGH505056D	5,6	44	82	6	-	-
NDPGH505057D	5,7	44	82	6	-	-
NDPGH505058D	5,8	44	82	6	-	-
NDPGH505059D	5,9	44	82	6	-	-
NDPGH50505953D	5,953	44	82	6	-	-
NDPGH505060D	6,0	44	82	6	-	-
NDPGH505061D	6,1	53	91	8	-	-
NDPGH505062D	6,2	53	91	8	-	-
NDPGH505063D	6,3	53	91	8	-	-
NDPGH5050635D	6,35	53	91	8	-	-
NDPGH505064D	6,4	53	91	8	-	-
NDPGH505065D	6,5	53	91	8	-	-
NDPGH50506528D	6,528	53	91	8	-	-
NDPGH505066D	6,6	53	91	8	-	-
NDPGH505067D	6,7	53	91	8	-	-
NDPGH50506747D	6,747	53	91	8	-	-
NDPGH505068D	6,8	53	91	8	M8x1,25	WH1~4
NDPGH505069D	6,9	53	91	8	M8x1,25	WH5~6
NDPGH505070D	7,0	53	91	8	M8x1,0	WH1~4
NDPGH505071D	7,1	53	91	8	M8x1,0	WH5~6
NDPGH50507144D	7,144	53	91	8	-	-
NDPGH505072D	7,2	53	91	8	-	-
NDPGH505073D	7,3	53	91	8	-	-
NDPGH505074D	7,4	53	91	8	-	-
NDPGH505075D	7,5	53	91	8	-	-
NDPGH50507541D	7,541	53	91	8	-	-
NDPGH505076D	7,6	53	91	8	-	-
NDPGH505077D	7,7	53	91	8	-	-

Applicable Work Materials

P			H		M	K	N
Carbon Steel ~HB225	Alloy Steel HB225~325	Prehardened Steel HRC30 ~ 50	Hardened Steel		Stainless	Cast Iron	Non-ferrous & Aluminum
			SKD61 ~HRC55	SKD11 HRC55~			
◎	◎	◎	○		◎	◎	○

○ : Good ◎ : Excellent

NDPGH505

NEW DOLPHIN GENERAL OIL HOLE DRILL

EDP No	SIZES (mm)				Applicable Tap		EDP No	SIZES (mm)				Applicable Tap	
	D	L1	L2	D2	Size	Limit		D	L1	L2	D2	Size	Limit
NDPGH505078D	7,8	53	91	8	-	-	NDPGH50511509D	11,509	71	118	12	-	-
NDPGH505079D	7,9	53	91	8	-	-	NDPGH505116D	11,6	71	118	12	-	-
NDPGH50507938D	7,938	53	91	8	-	-	NDPGH505117D	11,7	71	118	12	-	-
NDPGH505080D	8,0	53	91	8	-	-	NDPGH505118D	11,8	71	118	12	-	-
NDPGH505081D	8,1	61	103	10	-	-	NDPGH505119D	11,9	71	118	12	-	-
NDPGH505082D	8,2	61	103	10	-	-	NDPGH50511906D	11,906	71	118	12	-	-
NDPGH505083D	8,3	61	103	10	-	-	NDPGH505120D	12,0	71	118	12	M14x2,0	WH1~4
NDPGH50508334D	8,334	61	103	10	-	-	NDPGH505121D	12,1	77	124	14	M14x2,0	WH5~6
NDPGH505084D	8,4	61	103	10	-	-	NDPGH505122D	12,2	77	124	14	-	-
NDPGH50508433D	8,433	61	103	10	-	-	NDPGH505123D	12,3	77	124	14	-	-
NDPGH505085D	8,5	61	103	10	M10x1,5	WH1~4	NDPGH50512303D	12,303	77	124	14	-	-
NDPGH505086D	8,6	61	103	10	M10x1,5	WH5~6	NDPGH505124D	12,4	77	124	14	-	-
NDPGH505087D	8,7	61	103	10	-	-	NDPGH505125D	12,5	77	124	14	M14x1,5	WH1~4
NDPGH50508731D	8,731	61	103	10	-	-	NDPGH505126D	12,6	77	124	14	M14x1,5	WH5~6
NDPGH505088D	8,8	61	103	10	M10x1,25	WH1~4	NDPGH505127D	12,7	77	124	14	-	-
NDPGH505089D	8,9	61	103	10	M10x1,25	WH5~6	NDPGH505128D	12,8	77	124	14	-	-
NDPGH505090D	9,0	61	103	10	M10x1,0	WH1~4	NDPGH505129D	12,9	77	124	14	-	-
NDPGH505091D	9,1	61	103	10	M10x1,0	WH5~6	NDPGH505130D	13,0	77	124	14	-	-
NDPGH50509128D	9,128	61	103	10	-	-	NDPGH505131D	13,1	77	124	14	-	-
NDPGH505092D	9,2	61	103	10	-	-	NDPGH505132D	13,2	77	124	14	-	-
NDPGH505093D	9,3	61	103	10	-	-	NDPGH505133D	13,3	77	124	14	-	-
NDPGH50509347D	9,347	61	103	10	-	-	NDPGH505134D	13,4	77	124	14	-	-
NDPGH505094D	9,4	61	103	10	-	-	NDPGH505135D	13,5	77	124	14	-	-
NDPGH505095D	9,5	61	103	10	-	-	NDPGH505136D	13,6	77	124	14	-	-
NDPGH50509525D	9,525	61	103	10	-	-	NDPGH505137D	13,7	77	124	14	-	-
NDPGH505096D	9,6	61	103	10	-	-	NDPGH505138D	13,8	77	124	14	-	-
NDPGH505097D	9,7	61	103	10	-	-	NDPGH50513891D	13,891	77	124	14	-	-
NDPGH505098D	9,8	61	103	10	-	-	NDPGH505139D	13,9	77	124	14	-	-
NDPGH505099D	9,9	61	103	10	-	-	NDPGH505140D	14,0	77	124	14	M16x2,0	WH1~4
NDPGH50509922D	9,922	61	103	10	-	-	NDPGH505141D	14,1	83	133	16	M16x2,0	WH5~6
NDPGH505100D	10,0	61	103	10	-	-	NDPGH505142D	14,2	83	133	16	-	-
NDPGH505101D	10,1	71	118	12	-	-	NDPGH50514288D	14,288	83	133	16	-	-
NDPGH505102D	10,2	71	118	12	-	-	NDPGH505143D	14,3	83	133	16	-	-
NDPGH505103D	10,3	71	118	12	M12x1,75	WH1~2	NDPGH505144D	14,4	83	133	16	-	-
NDPGH50510319D	10,319	71	118	12	M12x1,75	WH3~4	NDPGH505145D	14,5	83	133	16	M16x1,5	WH1~4
NDPGH505104D	10,4	71	118	12	M12x1,75	WH5~6	NDPGH505146D	14,6	83	133	16	M16x1,5	WH5~6
NDPGH505105D	10,5	71	118	12	M12x1,5	WH1~4	NDPGH50514684D	14,684	83	133	16	-	-
NDPGH505106D	10,6	71	118	12	M12x1,5	WH5~6	NDPGH505147D	14,7	83	133	16	-	-
NDPGH505107D	10,7	71	118	12	-	-	NDPGH505148D	14,8	83	133	16	-	-
NDPGH50510716D	10,716	71	118	12	-	-	NDPGH505149D	14,9	83	133	16	-	-
NDPGH505108D	10,8	71	118	12	M12x1,25	WH1~4	NDPGH505150D	15,0	83	133	16	-	-
NDPGH505109D	10,9	71	118	12	M12x1,25	WH5~6	NDPGH50515081D	15,081	83	133	16	-	-
NDPGH505110D	11,0	71	118	12	M12x1,0	WH1~4	NDPGH505151D	15,1	83	133	16	-	-
NDPGH505111D	11,1	71	118	12	M12x1,0	WH5~6	NDPGH505152D	15,2	83	133	16	-	-
NDPGH5051113D	11,113	71	118	12	-	-	NDPGH505153D	15,3	83	133	16	-	-
NDPGH505112D	11,2	71	118	12	-	-	NDPGH505154D	15,4	83	133	16	-	-
NDPGH505113D	11,3	71	118	12	-	-	NDPGH50515478D	15,478	83	133	16	-	-
NDPGH505114D	11,4	71	118	12	-	-	NDPGH505155D	15,5	83	133	16	M18x2,5	WH1~4
NDPGH505115D	11,5	71	118	12	-	-	NDPGH505156D	15,6	83	133	16	M18x2,5	WH5~6

■ Applicable Work Materials

P			H		M	K	N
Carbon Steel ~HB225	Alloy Steel HB225~325	Prehardened Steel HRC30 ~ 50	Hardened Steel		Stainless	Cast Iron	Non-ferrous & Aluminum
			SKD61 ~HRC55	SKD11 HRC55~			
◎	◎	◎	○		◎	◎	○

○ : Good ◎ : Excellent

NDPGH505

NEW DOLPHIN GENERAL OIL HOLE DRILL

EDP No	SIZES (mm)				Applicable Tap	
	D	L1	L2	D2	Size	Limit
NDPGH505157D	15.7	83	133	16	-	-
NDPGH505158D	15.8	83	133	16	-	-
NDPGH50515875D	15.875	83	133	16	-	-
NDPGH505159D	15.9	83	133	16	-	-
NDPGH505160D	16.0	83	133	16	-	-
NDPGH50516272D	16.272	93	143	18	-	-
NDPGH505165D	16.5	93	143	18	M18x1.5	WH1~6
NDPGH50516669D	16.669	93	143	18	-	-
NDPGH505170D	17.0	93	143	18	-	-
NDPGH50517066D	17.066	93	143	18	-	-
NDPGH50517463D	17.463	93	143	18	-	-
NDPGH505175D	17.5	93	143	18	M20x2.5	WH1~6

EDP No	SIZES (mm)				Applicable Tap	
	D	L1	L2	D2	Size	Limit
NDPGH50517859D	17.859	93	143	18	-	-
NDPGH505180D	18.0	93	143	18	-	-
NDPGH50518256D	18.256	101	153	20	-	-
NDPGH505185D	18.5	101	153	20	M20x1.5	WH1~6
NDPGH50518654D	18.654	101	153	20	-	-
NDPGH505190D	19.0	101	153	20	-	-
NDPGH5051905D	19.050	101	153	20	-	-
NDPGH5051925D	19.25	101	153	20	-	-
NDPGH50519447D	19.447	101	153	20	-	-
NDPGH505195D	19.5	101	153	20	M22x2.5	WH1~6
NDPGH50519844D	19.844	101	153	20	-	-
NDPGH505200D	20.0	101	153	20	-	-

■ Applicable Work Materials

P			H		M	K	N
Carbon Steel ~HB225	Alloy Steel HB225~325	Prehardened Steel HRc30 ~ 50	Hardened Steel		Stainless	Cast Iron	Non-ferrous & Aluminum
			SKD61 ~HRc55	SKD11 HRc55~			
◎	◎	◎	○		◎	◎	○

○ : Good ◎ : Excellent

NDPGH508

NEW DOLPHIN GENERAL OIL HOLE DRILL

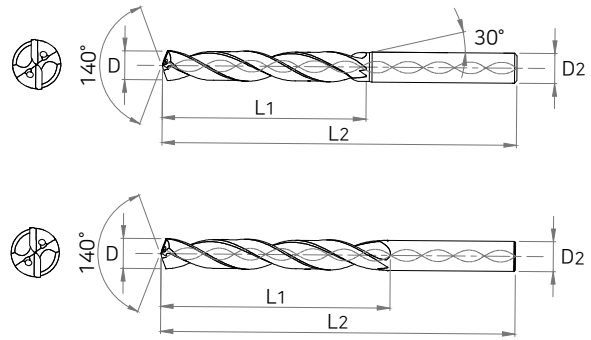
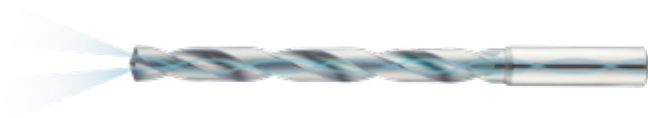

Tolerance

Cutting Dia (mm)		Shank Dia h6
~ D3	+0.002~+0.012	
D3.1~D6	+0.004~+0.016	
D6.1~D10	+0.006~+0.021	
D10.1~D18	+0.007~+0.025	
D18.1~D20	+0.008~+0.029	

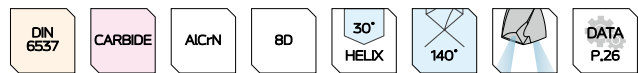

EDP No	SIZES (mm)				Applicable Tap	
	D	L1	L2	D2	Size	Limit
NDPGH508030D	3,0	31	74	6	-	-
NDPGH508031D	3,1	36	81	6	-	-
NDPGH50803175D	3,175	36	81	6	-	-
NDPGH508032D	3,2	36	81	6	-	-
NDPGH508033D	3,3	36	81	6	M4x0,7	WH1~4
NDPGH508034D	3,4	36	81	6	M4x0,7	WH 5~6
NDPGH508035D	3,5	36	81	6	-	-
NDPGH50803572D	3,572	41	86	6	-	-
NDPGH508036D	3,6	41	86	6	-	-
NDPGH508037D	3,7	41	86	6	-	-
NDPGH508038D	3,8	41	86	6	-	-
NDPGH508039D	3,9	41	86	6	-	-
NDPGH50803969D	3,969	41	86	6	-	-
NDPGH508040D	4,0	41	86	6	-	-
NDPGH50804039D	4,039	46	91	6	-	-
NDPGH508041D	4,1	46	91	6	-	-
NDPGH508042D	4,2	46	91	6	M5x0,8	WH1~4
NDPGH508043D	4,3	46	91	6	M5x0,8	WH5~6
NDPGH50804366D	4,366	46	91	6	-	-
NDPGH508044D	4,4	46	91	6	-	-
NDPGH508045D	4,5	46	91	6	-	-
NDPGH508046D	4,6	51	96	6	-	-
NDPGH508047D	4,7	51	96	6	-	-
NDPGH50804763D	4,763	51	96	6	-	-
NDPGH508048D	4,8	51	96	6	-	-
NDPGH508049D	4,9	51	96	6	-	-
NDPGH508050D	5,0	51	96	6	M6x1,0	WH1~4
NDPGH508051D	5,1	57	102	6	M6x1,0	WH5~6
NDPGH50805159D	5,159	57	102	6	-	-
NDPGH508052D	5,2	57	102	6	-	-
NDPGH508053D	5,3	57	102	6	-	-

EDP No	SIZES (mm)				Applicable Tap	
	D	L1	L2	D2	Size	Limit
NDPGH508054D	5,4	57	102	6	-	-
NDPGH508055D	5,5	57	102	6	-	-
NDPGH50805556D	5,558	62	107	6	-	-
NDPGH508056D	5,6	62	107	6	-	-
NDPGH508057D	5,7	62	107	6	-	-
NDPGH508058D	5,8	62	107	6	-	-
NDPGH508059D	5,9	62	107	6	-	-
NDPGH50805953D	5,953	62	107	6	-	-
NDPGH508060D	6,0	62	107	6	-	-
NDPGH508061D	6,1	71	116	8	-	-
NDPGH508062D	6,2	71	116	8	-	-
NDPGH508063D	6,3	71	116	8	-	-
NDPGH5080635D	6,35	71	116	8	-	-
NDPGH508064D	6,4	71	116	8	-	-
NDPGH508065D	6,5	71	116	8	-	-
NDPGH50806528D	6,528	71	116	8	-	-
NDPGH508066D	6,6	71	116	8	-	-
NDPGH508067D	6,7	71	116	8	-	-
NDPGH50806747D	6,747	71	116	8	-	-
NDPGH508068D	6,8	71	116	8	M8x1,25	WH1~4
NDPGH508069D	6,9	71	116	8	M8x1,25	WH5~6
NDPGH508070D	7,0	71	116	8	M8x1,0	WH1~4
NDPGH508071D	7,1	81	126	8	M8x1,0	WH5~6
NDPGH50807144D	7,144	81	126	8	-	-
NDPGH508072D	7,2	81	126	8	-	-
NDPGH508073D	7,3	81	126	8	-	-
NDPGH508074D	7,4	81	126	8	-	-
NDPGH508075D	7,5	81	126	8	-	-
NDPGH50807541D	7,541	81	126	8	-	-
NDPGH508076D	7,6	81	126	8	-	-
NDPGH508077D	7,7	81	126	8	-	-

Applicable Work Materials

P			H		M	K	N
Carbon Steel ~HB225	Alloy Steel HB225~325	Prehardened Steel HRC30 ~ 50	Hardened Steel		Stainless	Cast Iron	Non-ferrous & Aluminum
			SKD61 ~HRC55	SKD11 HRC55~			
◎	◎	◎	○		◎	◎	○

○ : Good ◎ : Excellent

NDPGH508

NEW DOLPHIN GENERAL OIL HOLE DRILL

EDP No	SIZES (mm)				Applicable Tap	
	D	L1	L2	D2	Size	Limit
NDPGH508078D	7.8	81	126	8	-	-
NDPGH508079D	7.9	81	126	8	-	-
NDPGH50807938D	7.938	81	126	8	-	-
NDPGH508080D	8.0	81	126	8	-	-
NDPGH508081D	8.1	92	137	10	-	-
NDPGH508082D	8.2	92	137	10	-	-
NDPGH508083D	8.3	92	137	10	-	-
NDPGH50808334D	8.334	92	137	10	-	-
NDPGH508084D	8.4	92	137	10	-	-
NDPGH50808433D	8.433	92	137	10	-	-
NDPGH508085D	8.5	92	137	10	M10x1.5	WH1~4
NDPGH508086D	8.6	92	137	10	M10x1.5	WH5~6
NDPGH508087D	8.7	92	137	10	-	-
NDPGH50808731D	8.731	92	137	10	-	-
NDPGH508088D	8.8	92	137	10	M10x1.25	WH1~4
NDPGH508089D	8.9	92	137	10	M10x1.25	WH5~6
NDPGH508090D	9.0	92	137	10	M10x1.0	WH1~4
NDPGH508091D	9.1	102	147	10	M10x1.0	WH5~6
NDPGH50809128D	9.128	102	147	10	-	-
NDPGH508092D	9.2	102	147	10	-	-
NDPGH508093D	9.3	102	147	10	-	-
NDPGH50809347D	9.347	102	147	10	-	-
NDPGH508094D	9.4	102	147	10	-	-
NDPGH508095D	9.5	102	147	10	-	-
NDPGH50809525D	9.525	102	147	10	-	-
NDPGH508096D	9.6	102	147	10	-	-
NDPGH508097D	9.7	102	147	10	-	-
NDPGH508098D	9.8	102	147	10	-	-
NDPGH508099D	9.9	102	147	10	-	-
NDPGH50809922D	9.922	102	147	10	-	-
NDPGH508100D	10.0	102	147	10	-	-
NDPGH508101D	10.1	113	158	12	-	-
NDPGH508102D	10.2	113	158	12	-	-
NDPGH508103D	10.3	113	158	12	M12x1.75	WH1~2
NDPGH50810319D	10.319	113	158	12	M12x1.75	WH3~4
NDPGH508104D	10.4	113	158	12	M12x1.75	WH5~6
NDPGH508105D	10.5	113	158	12	M12x1.5	WH1~4
NDPGH508106D	10.6	113	158	12	M12x1.5	WH5~6
NDPGH508107D	10.7	113	158	12	-	-
NDPGH50810716D	10.716	113	158	12	-	-
NDPGH508108D	10.8	113	158	12	M12x1.25	WH1~4
NDPGH508109D	10.9	113	158	12	M12x1.25	WH5~6
NDPGH508110D	11.0	113	158	12	M12x1.0	WH1~4
NDPGH508111D	11.1	123	168	12	M12x1.0	WH5~6
NDPGH50811113D	11.113	123	168	12	-	-
NDPGH508112D	11.2	123	168	12	-	-
NDPGH508113D	11.3	123	168	12	-	-
NDPGH508114D	11.4	123	168	12	-	-
NDPGH508115D	11.5	123	168	12	-	-

EDP No	SIZES (mm)				Applicable Tap	
	D	L1	L2	D2	Size	Limit
NDPGH50811509D	11.509	123	168	12	-	-
NDPGH508116D	11.6	123	168	12	-	-
NDPGH508117D	11.7	123	168	12	-	-
NDPGH508118D	11.8	123	168	12	-	-
NDPGH508119D	11.9	123	168	12	-	-
NDPGH50811906D	11.906	123	168	12	-	-
NDPGH508120D	12.0	123	168	12	M14x2.0	WH1~4
NDPGH508121D	12.1	134	179	14	M14x2.0	WH5~6
NDPGH508122D	12.2	134	179	14	-	-
NDPGH508123D	12.3	134	179	14	-	-
NDPGH50812303D	12.303	134	179	14	-	-
NDPGH508124D	12.4	134	179	14	-	-
NDPGH508125D	12.5	134	179	14	M14x1.5	WH1~4
NDPGH508126D	12.6	134	179	14	M14x1.5	WH5~6
NDPGH508127D	12.7	134	179	14	-	-
NDPGH508128D	12.8	134	179	14	-	-
NDPGH508129D	12.9	134	179	14	-	-
NDPGH508130D	13.0	134	179	14	-	-
NDPGH508131D	13.1	144	189	14	-	-
NDPGH508132D	13.2	144	189	14	-	-
NDPGH508133D	13.3	144	189	14	-	-
NDPGH508134D	13.4	144	189	14	-	-
NDPGH508135D	13.5	144	189	14	-	-
NDPGH508136D	13.6	144	189	14	-	-
NDPGH508137D	13.7	144	189	14	-	-
NDPGH508138D	13.8	144	189	14	-	-
NDPGH50813891D	13.891	144	189	14	-	-
NDPGH508139D	13.9	144	189	14	-	-
NDPGH508140D	14.0	144	189	14	M16x2.0	WH1~4
NDPGH508141D	14.1	155	200	16	M16x2.0	WH5~6
NDPGH508142D	14.2	155	200	16	-	-
NDPGH50814288D	14.288	155	200	16	-	-
NDPGH508143D	14.3	155	200	16	-	-
NDPGH508144D	14.4	155	200	16	-	-
NDPGH508145D	14.5	155	200	16	M16x1.5	WH1~4
NDPGH508146D	14.6	155	200	16	M16x1.5	WH5~6
NDPGH50814684D	14.684	155	200	16	-	-
NDPGH508147D	14.7	155	200	16	-	-
NDPGH508148D	14.8	155	200	16	-	-
NDPGH508149D	14.9	155	200	16	-	-
NDPGH508150D	15.0	155	200	16	-	-
NDPGH50815081D	15.081	165	210	16	-	-
NDPGH508151D	15.1	165	210	16	-	-
NDPGH508152D	15.2	165	210	16	-	-
NDPGH508153D	15.3	165	210	16	-	-
NDPGH508154D	15.4	165	210	16	-	-
NDPGH50815478D	15.478	165	210	16	-	-
NDPGH508155D	15.5	165	210	16	M18x2.5	WH1~4
NDPGH508156D	15.6	165	210	16	M18x2.5	WH5~6

■ Applicable Work Materials

P			H		M	K	N
Carbon Steel ~HB225	Alloy Steel HB225~325	Prehardened Steel HRC30 ~ 50	Hardened Steel		Stainless	Cast Iron	Non-ferrous & Aluminum
			SKD61 ~HRC55	SKD11 HRC55~			
◎	◎	◎	○		◎	◎	○

○ : Good ◎ : Excellent

NDPGH508

NEW DOLPHIN GENERAL OIL HOLE DRILL

EDP No	SIZES (mm)				Applicable Tap	
	D	L1	L2	D2	Size	Limit
NDPGH508157D	15,7	165	210	16	-	-
NDPGH508158D	15,8	165	210	16	-	-
NDPGH50815875D	15,875	165	210	16	-	-

EDP No	SIZES (mm)				Applicable Tap	
	D	L1	L2	D2	Size	Limit
NDPGH508159D	15,9	165	210	16	-	-
NDPGH508160D	16,0	165	210	16	-	-

■ Applicable Work Materials

P			H		M	K	N
Carbon Steel ~HB225	Alloy Steel HB225~325	Prehardened Steel HRc30 ~ 50	Hardened Steel		Stainless	Cast Iron	Non-ferrous & Aluminum
			SKD61 ~HRc55	SKD11 HRc55~			
◎	◎	◎	○		◎	◎	○

○ : Good ◎ : Excellent

Recommended Cutting Conditions

NDPG 503, 504, 507 SERIES ► External Coolant

workpiece	P						K				M	
	Carbon Steels, Alloy Steels SS400, SM50C, SCM, SCr ~900N/mm ² / ~HRC 28		Alloy Steels SCM, SCr ~1,100N/mm ² HRC 28~35		Alloy Steels, Hardened Steels ~HRC40		Cast Iron ~350N/mm ²		Ductile Iron 400~600N/mm ²		Stainless Steels SUS300, SUS400	
Vc	70~120m/min		50~90m/min		25~60m/min		70~120m/min		55~100m/min		35~70m/min	
Dia.	RPM	fn (mm/rev)	RPM	fn (mm/rev)	RPM	fn (mm/rev)	RPM	fn (mm/rev)	RPM	fn (mm/rev)	RPM	fn (mm/rev)
2	11,100	0.06	8,000	0.06	4,000	0.06	11,100	0.06	10,400	0.06	8,400	0.06
4	7,600	0.14	5,600	0.14	3,400	0.1	7,600	0.14	6,200	0.14	4,200	0.14
6	5,000	0.17	3,700	0.17	2,300	0.14	5,000	0.17	4,100	0.21	2,800	0.17
8	3,800	0.21	2,800	0.21	1,700	0.18	3,800	0.21	3,100	0.24	2,100	0.21
10	3,000	0.25	2,200	0.25	1,400	0.22	3,000	0.25	2,500	0.26	1,700	0.25
12	2,500	0.27	1,900	0.27	1,100	0.24	2,500	0.27	2,100	0.28	1,400	0.27
14	2,200	0.29	1,600	0.29	1,000	0.26	2,200	0.29	1,800	0.31	1,200	0.29
16	1,900	0.31	1,400	0.31	800	0.29	1,900	0.31	1,500	0.33	1,000	0.31
18	1,700	0.33	1,200	0.33	800	0.32	1,700	0.33	1,400	0.35	900	0.33
20	1,500	0.35	1,100	0.35	700	0.34	1,500	0.35	1,200	0.37	800	0.35

※ In actual machining, the condition should be adjusted according to the machining shape, purpose and machine type.

* 7D : apply 75 % of above cutting condition

NDPGH 503, 505, 508 SERIES ► Internal Coolant

workpiece	P						K				M	
	Carbon Steels, Alloy Steels SS400, SM50C, SCM, SCr ~900N/mm ² / ~HRC 28		Alloy Steels SCM, SCr ~1,100N/mm ² HRC 28~35		Alloy Steels, Hardened Steels ~HRC40		Cast Iron ~350N/mm ²		Ductile Iron 400~600N/mm ²		Stainless Steels SUS300, SUS400	
Vc	80~120m/min		60~90m/min		30~60m/min		80~120m/min		60~100m/min		40~70m/min	
Dia.	RPM	fn (mm/rev)	RPM	fn (mm/rev)	RPM	fn (mm/rev)	RPM	fn (mm/rev)	RPM	fn (mm/rev)	RPM	fn (mm/rev)
3	10,600	0.09	8,000	0.09	4,800	0.08	10,600	0.09	8,500	0.09	5,800	0.09
4	8,000	0.14	6,000	0.14	3,600	0.1	8,000	0.14	6,400	0.14	4,400	0.14
6	5,300	0.17	4,000	0.17	2,400	0.14	5,300	0.17	4,200	0.21	2,900	0.17
8	4,000	0.21	3,000	0.21	1,800	0.18	4,000	0.21	3,200	0.24	2,200	0.21
10	3,200	0.25	2,400	0.25	1,400	0.22	3,200	0.25	2,500	0.26	1,800	0.25
12	2,700	0.27	2,000	0.27	1,200	0.24	2,700	0.27	2,100	0.28	1,500	0.27
14	2,300	0.29	1,700	0.29	1,000	0.26	2,300	0.29	1,800	0.31	1,300	0.29
16	2,000	0.31	1,500	0.31	900	0.29	2,000	0.31	1,600	0.33	1,100	0.31
18	1,800	0.33	1,300	0.33	800	0.32	1,800	0.33	1,400	0.35	1,000	0.33
20	1,600	0.35	1,200	0.35	700	0.34	1,600	0.35	1,300	0.37	900	0.35

※ In actual machining, the condition should be adjusted according to the machining shape, purpose and machine type.

* 8D : apply 75 % of above cutting condition



HQ & Changwon Factory

172, Sahwa-ro, Uichang-gu, Changwon-si, Gyeongsangnam-do, Korea [51389]

HQ : TEL +82-55-286-0905 FAX : +82-55-286-0978

WIDIN Viet Nam(Office & Factory)

Lot CN5, Hop Thinh Industrial Zone, Hop Thinh Commune, Hiep Hoa District,
Bac Giang Province, Viet Nam

TEL : +84-20-4248-4883

↳ **Viet Nam, Ha Noi Office**

8th Floor – Hoang Ngoc Building, Lot C2C, Cau Giay Focus Areas of Information
Technology, Dich Vong Hau Ward, Cau Giay District, Ha Noi City, Viet Nam

TEL : +84-24-6287-3828

↳ **Viet Nam, Ho Chi Minh Office**

4th Floor – Hai Au Building, 39B Truong Son, Ward 4, Tan Binh isDtrict,
Ho Chi Minh City, Viet Nam

TEL : +84-28-6297-3858