

NPN

New Product News



CHASE4MILL

90° MILLING

90° Shoulder Mill 4 Cutting Edge Insert with High Ramping Capability

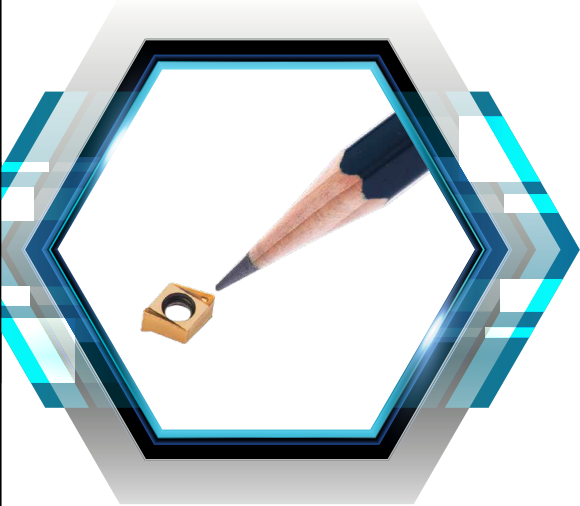

KEY POINT

TaeguTec introduces a new and wide line of inserts and cutters, the CHASE-4-MILL 4NK(H)T line.

Due to the high acclaim of the current 4NKT 06 line of milling products, TaeguTec has introduced the **CHASE-4-MILL 4NK(H)T 04, 09, 11 and 14** line of inserts and cutters.

The 4NK(H)T 04, 09, 11 and 14 inserts and cutters have the same features as the 4NKT 06 line-up but in a wider range of sizes to cover various applications.

These inserts are designed in several types; **M** for use in general purpose conditions, **ML** for low power machining in unstable setups and long overhangs. **HF** for high feed rate operations, **PNR-M** which has a wiper cutting edge for optimal surface roughness, and the new line also includes an **AL** type for aluminum machining.

The **CHASE-4-MILL's** 4NK(H)T 04, 06, 09, 11 and 14 line covers a wide range of applications and machining conditions, making it not only suitable for general-purpose machining but also the mold and die, automotive and miniature industries' requirements such as facing, shouldering, slotting to ramping.

* As part of the new campaign, the design for the new **CHASE-4-MILL** line highlights TaeguTec's new direction.

* The new **CHASE-4-MILL** logo will be applied to the 4NK(H)T 06 inserts and cutters as well.

For further technical inquiries, please contact your product manager.

Features

- True 90° shoulder milling capability
- High axial and radial positive geometry
- High ramp down angle
- High productivity due to fine pitch cutters

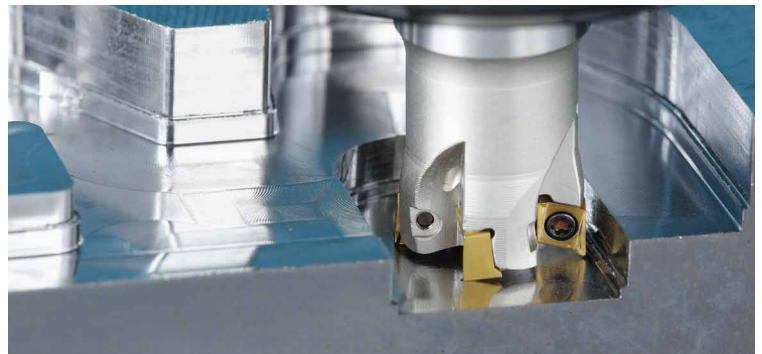

Cutters



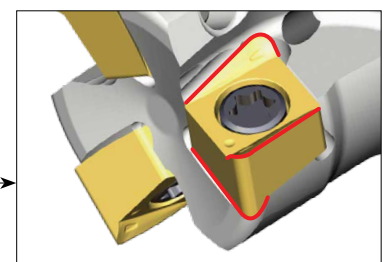

- Internal coolant system
- Wide bottom pocket for improved machining stability and cutter durability
- Strong screw allows for stable clamping

Inserts

- Double-sided 4 corner insert
- High positive geometry for low cutting force
- Thick and strong insert
- Strong cutting edge due to crossed edges between the top and the bottom →
- High feed rate HF means better productivity



CHASE-4-MILL cutter diameter range

Cutter type	Diameter Range			
		M 		S 
4NKT 04	Ø8-Ø40	Ø10-Ø25	Ø32-Ø40	Ø10-Ø16
4NK(H)T 06	Ø16-Ø40	Ø16-Ø40	Ø32-Ø63	Ø16
4NK(H)T 09	Ø20-Ø40	Ø20-Ø40	Ø40-Ø80	-
4NKT 11	Ø25-Ø40	Ø25-Ø40	Ø40-Ø80	-
4NKT 14	Ø32-Ø40	Ø32-Ø40	Ø50-Ø80	-

CHASE-4-MILL application range

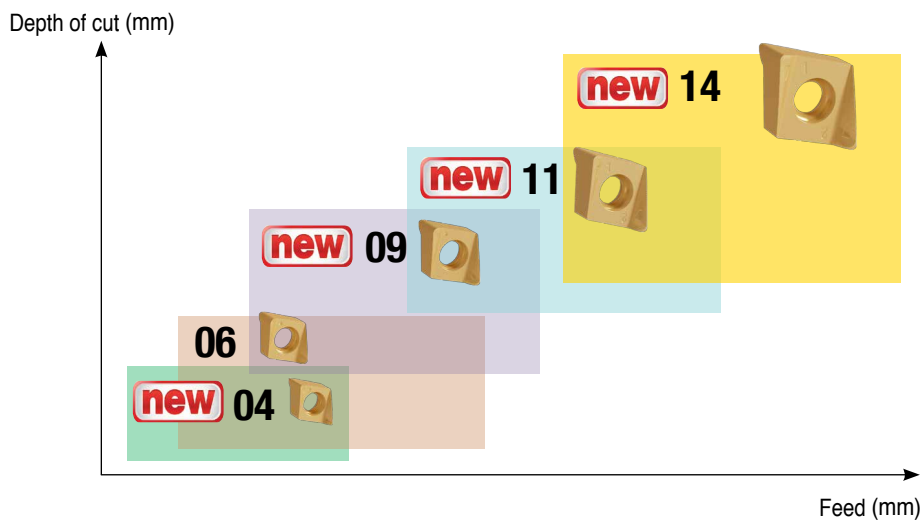



4N TF90-04

Face mills

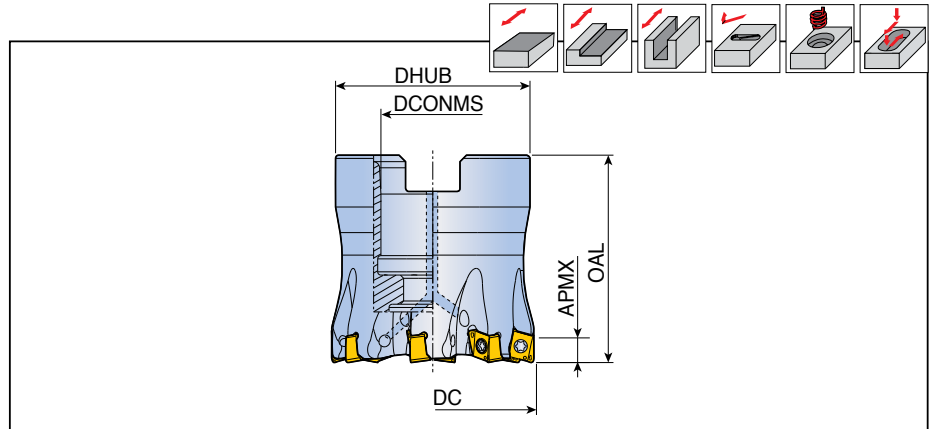
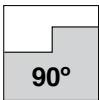

Designation		Dimension (mm)					Coolant	Arbor type	Kg	Mounting bolt	Insert
		DC	DCONMS	DHUB	OAL	APMX					
4N TF90- 832-16R-04	8	32	16	30	32	3.5	●	A	0.1	SH M8x25	4NKT 0402....
1040-16R-04	10	40	16	38	40	3.5	●	A	0.2	SH M8x25	

• Cutter body for '4NKT 040212R-HF' insert should be modified with body corner radius 1.2 mm

Spare parts

Designation	Screw	Wrench			
4N TF90-04	TS 18041I/HG	TD 6P			

4N TF90-09



Face mills

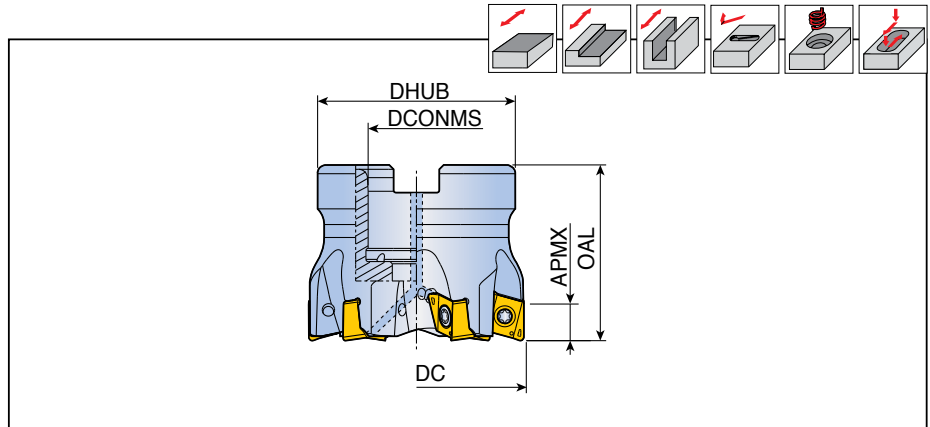
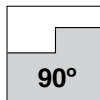
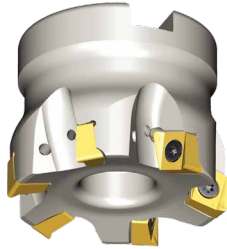

Designation		Dimension (mm)					Coolant	Arbor type	Kg	Mounting bolt	Insert
		DC	DCONMS	DHUB	OAL	APMX					
4N TF90-540-16R-09	5	40	16	38	40	8.0	•	A	0.3	SH M8x25	4NK(H)T 0904...
650-22R-09	6	50	22	45	40	8.0	•	A	0.3	LH M10x25	
763-22R-09	7	63	22	47	40	8.0	•	A	0.5	LH M10x25	
980-27R-09	9	80	27	58	50	8.0	•	A	1.1	SH M12x35	

• Cutter body for '4NKT 090432R-HF' insert should be modified with body corner radius 3.2 mm

Spare parts

Designation	Screw	Wrench	Wrench handle		
4N TF90-09	TS 35A088I/HG	TBLD T10P-W6	THND 6W		



4N TF90-11

Face mills

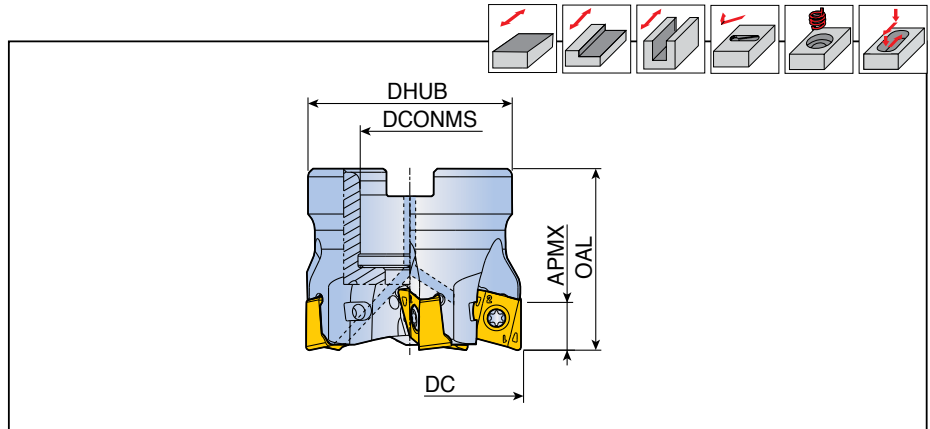
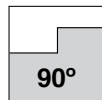
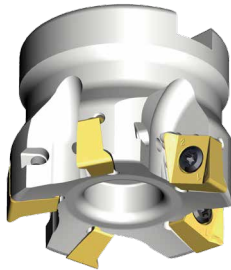

Designation		Dimension (mm)					Coolant	Arbor type	Kg	Mounting bolt	Insert
		DC	DCONMS	DHUB	OAL	APMX					
4N TF90- 440-16R-11	4	40	16	38	40	10.5	●	A	0.2	SH M8x30	4NKT 1106...
450-22R-11	4	50	22	45	40	10.5	●	A	0.3	LH M10x25	
550-22R-11	5	50	22	45	40	10.5	●	A	0.3	LH M10x25	
463-22R-11	4	63	22	47	40	10.5	●	A	0.6	LH M10x25	
663-22R-11	6	63	22	47	40	10.5	●	A	0.5	LH M10x25	
480-27R-11	4	80	27	58	50	10.5	●	A	1.1	SH M12x35	
880-27R-11	8	80	27	58	50	10.5	●	A	1.0	SH M12x35	

• Cutter body for '4NKT 110640R-HF' insert should be modified with body corner radius 4.0 mm

Spare parts

Designation	Screw	Wrench	Wrench handle		
4N TF90-11	TS 40093I/HG	TBLD T15-W6	SW6-T		



4N TF90-14

Face mills

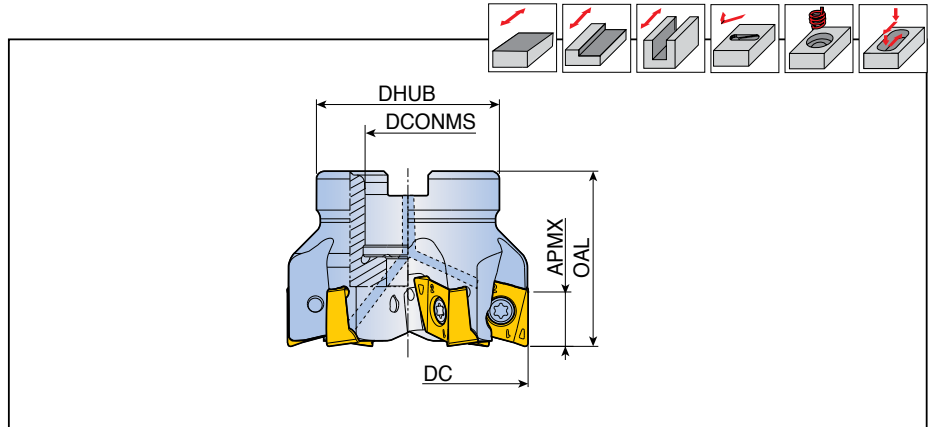
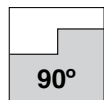
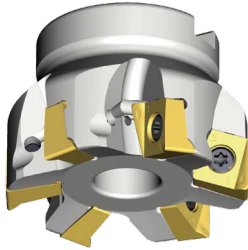

Designation		Dimension (mm)					Coolant	Arbor type	Kg	Mounting bolt	Insert
		DC	DCONMS	DHUB	OAL	APMX					
4N TF90-450-22R-14	4	50	22	45	45	13.8	●	A	0.4	SH M10x25	4NKT 1407....
463-22R-14	4	63	22	47	45	13.8	●	A	0.6	SH M10x25	
663-22R-14	6	63	22	47	45	13.8	●	A	0.6	SH M10x25	
580-27R-14	5	80	27	58	50	13.8	●	A	1.0	SH M12x35	
780-27R-14	7	80	27	58	50	13.8	●	A	1.0	SH M12x35	

• Cutter body for '4NKT 140750R-HF' insert should be modified with body corner radius 5.0 mm

Spare parts

Designation	Screw	Wrench	Wrench handle		
4N TF90-14	TS 50A121I/HG	TBLD T20-W6	SW6-T		

4N TE90-04



End mills

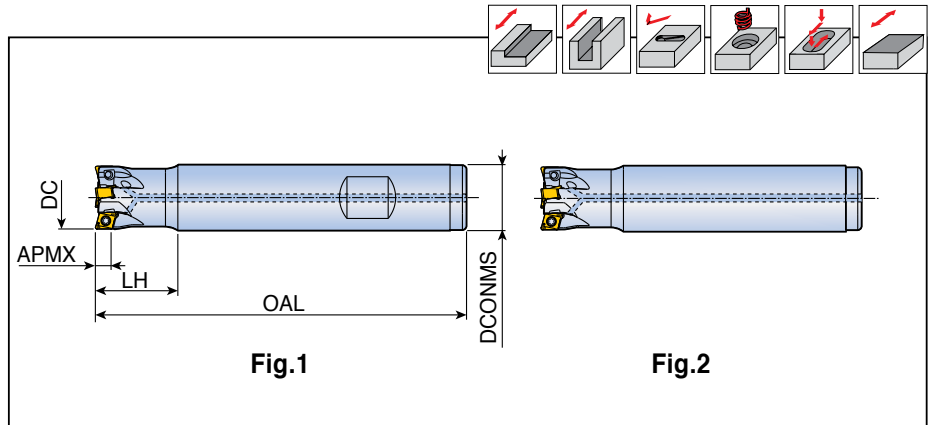
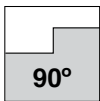
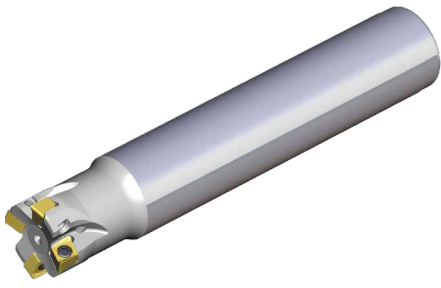

Designation	✱	Dimension (mm)					Coolant	Fig.	Insert
		DC	DCONMS	OAL	LH	APMX			
4N TE90- 108-08-04	1	8	8	80	17	3.5	●	2	4NKT 0402...
210-10-04	2	10	10	80	17	3.5	●	2	
211-10-04	2	11	10	80	17	3.5	●	2	
212-12-04	2	12	12	80	18	3.5	●	2	
312-12-04	3	12	12	80	18	3.5	●	2	
313-12-04	3	13	12	90	20	3.5	●	2	
316-16-04	3	16	16	90	20	3.5	●	2	
416-W16-04	4	16	16	90	20	3.5	●	1	
420-20-04-L	4	20	20	160	25	3.5	●	2	
520-W20-04	5	20	20	105	25	3.5	●	1	
725-W25-04	7	25	25	120	30	3.5	●	1	
832-W25-04	8	32	25	130	35	3.5	●	1	
1040-W32-04	10	40	32	140	40	3.5	●	1	

• Cutter body for '4NKT 040212R-HF' insert should be modified with body corner radius 1.2 mm



4N TE90-M-04

Modular heads for T-FLEXTEC

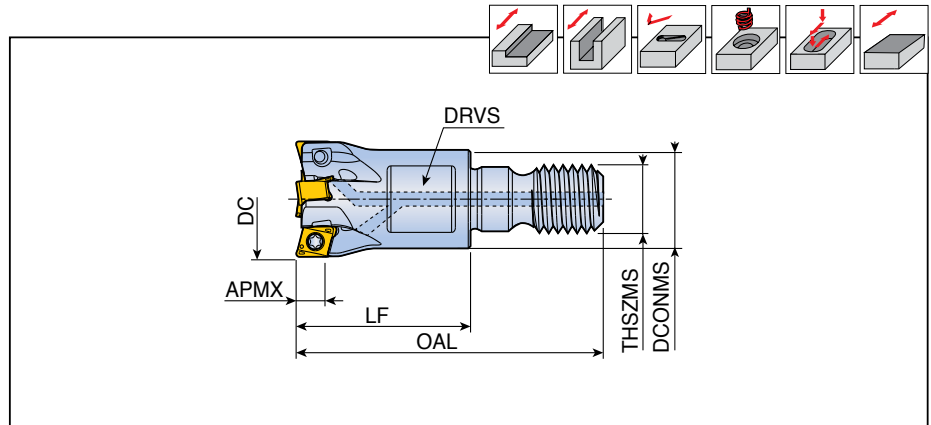
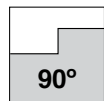
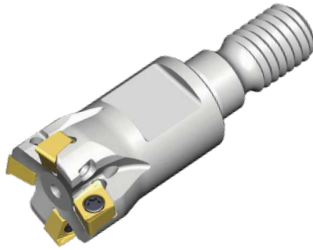

Designation		Dimension (mm)							Coolant	Insert
		DC	DCONMS	LF	OAL	THSZMS	APMX	DRVS		
4N TE90- 210-M06-04	2	10	9.7	17	31.5	M06	3.5	8	●	4NKT 0402...
211-M06-04	2	11	9.7	17	31.5	M06	3.5	8	●	
312-M06-04	3	12	11	17	31.5	M06	3.5	8	●	
313-M06-04	3	13	11	17	31.5	M06	3.5	8	●	
416-M08-04	4	16	13	23	40.5	M08	3.5	10	●	
520-M10-04	5	20	18	23	43	M10	3.5	15	●	
725-M12-04	7	25	21	27	49	M12	3.5	17	●	

- Cutter body for '4NKT 040212R-HF' insert should be modified with body corner radius 1.2 mm
- Matched with T-FLEXTEC holder

Spare parts

Designation	Screw	Wrench			
	4N TE90-04	TS 180411/HG	TD 6P		



4N TE90-S-04

Modular heads for MAXI-RUSH

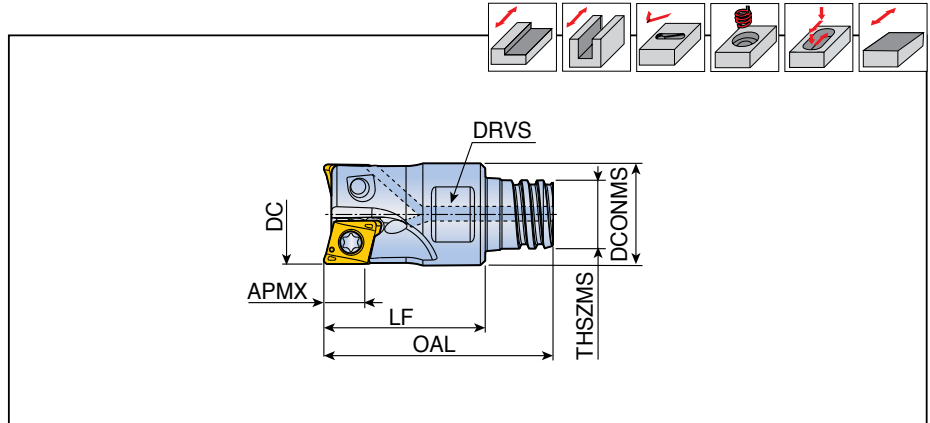
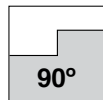
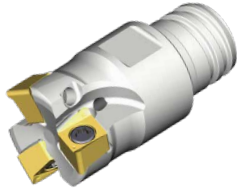

Designation		Dimension (mm)							Coolant	Insert
		DC	DCONMS	LF	OAL	THSZMS	APMX	DRVS		
4N TE90- 210-S06-04	2	10	9.6	15	21.3	S06	3.5	8	●	4NKT 0402...
312-S08-04	3	12	11.5	16	23.5	S08	3.5	10	●	
416-S10-04	4	16	15.2	20	31.3	S10	3.5	13	●	

- Cutter body for '4NKT 040212R-HF' insert should be modified with body corner radius 1.2 mm
- Matched with MAXI-RUSH holder

Spare parts

Designation	Screw	Wrench			
4N TE90-04	TS 18041/HG	TD 6P			

4N TE90-09

End mills

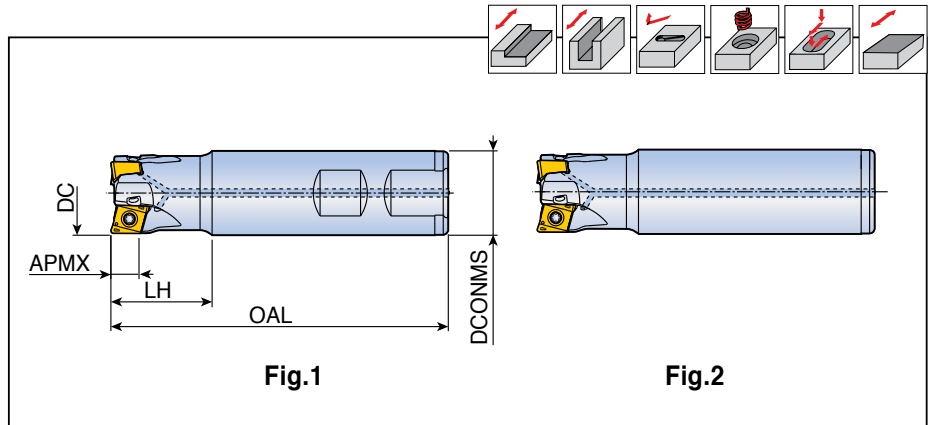
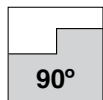

Designation	Symbol	Dimension (mm)					Coolant	Fig.	Insert
		DC	DCONMS	OAL	LH	APMX			
4N TE90- 220-W20-09	2	20	20	100	30	8.0	●	1	4NK(H)T 0904...
220-20-09-L170	2	20	20	170	30	8.0	●	2	
225-W25-09	2	25	25	100	30	8.0	●	1	
225-25-09-L200	2	25	25	200	40	8.0	●	2	
325-W25-09	3	25	25	100	30	8.0	●	1	
325-25-09-L210	3	25	25	210	30	8.0	●	2	
332-W32-09	3	32	32	110	40	8.0	●	1	
332-32-09-L250	3	32	32	250	40	8.0	●	2	
432-W25-09	4	32	25	130	35	8.0	●	1	
432-25-09-L200	4	32	25	200	40	8.0	●	2	
432-W32-09	4	32	32	110	40	8.0	●	1	
440-W32-09	4	40	32	115	40	8.0	●	1	
440-32-09-L250	4	40	32	250	40	8.0	●	2	
540-W32-09	5	40	32	115	40	8.0	●	1	

• Cutter body for '4NKT 090432R-HF' insert should be modified with body corner radius 3.2 mm



4N TE90-M-09

Modular heads for T-FLEXTEC

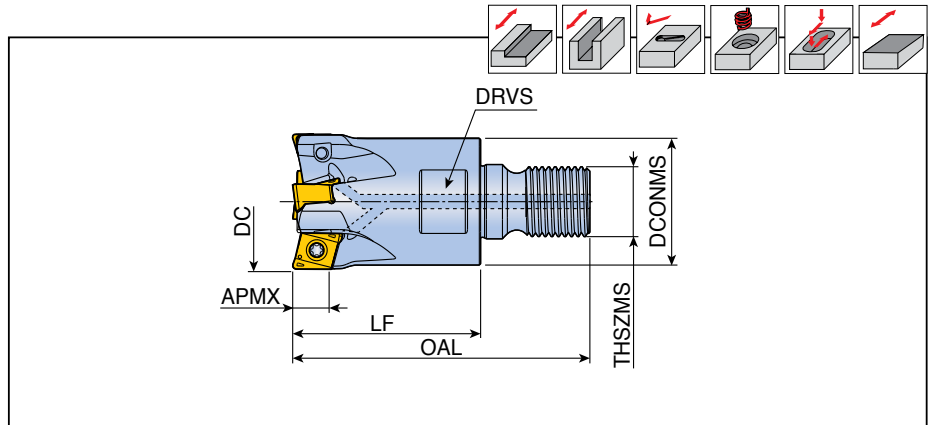
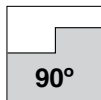

Designation		Dimension (mm)							Coolant	Insert
		DC	DCONMS	LF	OAL	THSZMS	APMX	DRVS		
4N TE90- 220-M10-09	2	20	18	30	50	M10	8.0	15	●	4NK(H)T 0904...
325-M12-09	3	25	21	35	57	M12	8.0	17	●	
432-M16-09	4	32	29	43	68	M16	8.0	25	●	
540-M16-09	5	40	29	43	68	M16	8.0	25	●	

- Cutter body for '4NKT 090432R-HF' insert should be modified with body corner radius 3.2 mm
- Matched with T-FLEXTEC holder

Spare parts

Designation	Screw	Wrench	Wrench handle		
4N TE90-09	TS 35A088I/HG	TBLD T10P-W6	THND 6W		



4N TE90-11

End mills

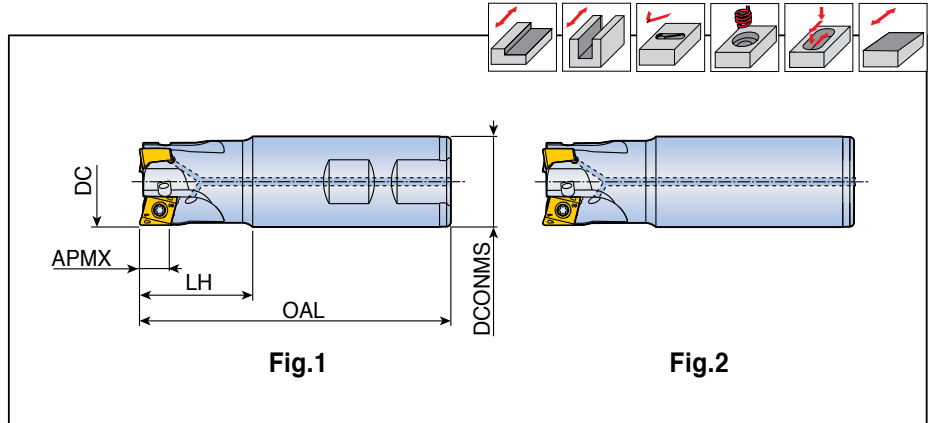
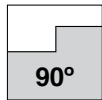
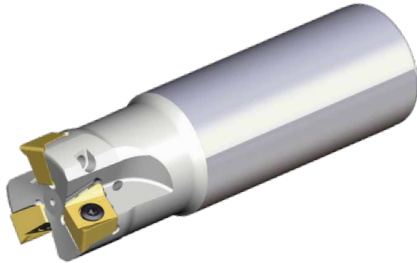

Designation	✎	Dimension (mm)					Coolant	Fig.	Insert
		DC	DCONMS	OAL	LH	APMX			
4N TE90- 225-W25-11	2	25	25	100	30	10.5	●	1	4NKT 1106...
225-25-11-L200	2	25	25	200	40	10.5	●	2	
332-W32-11	3	32	32	110	40	10.5	●	1	
440-W32-11	4	40	32	115	40	10.5	●	1	
440-32-11-L200	4	40	32	200	40	10.5	●	2	

• Cutter body for '4NKT 110640R-HF' insert should be modified with body corner radius 4.0 mm



4N TE90-M-11

Modular heads for T-FLEXTEC

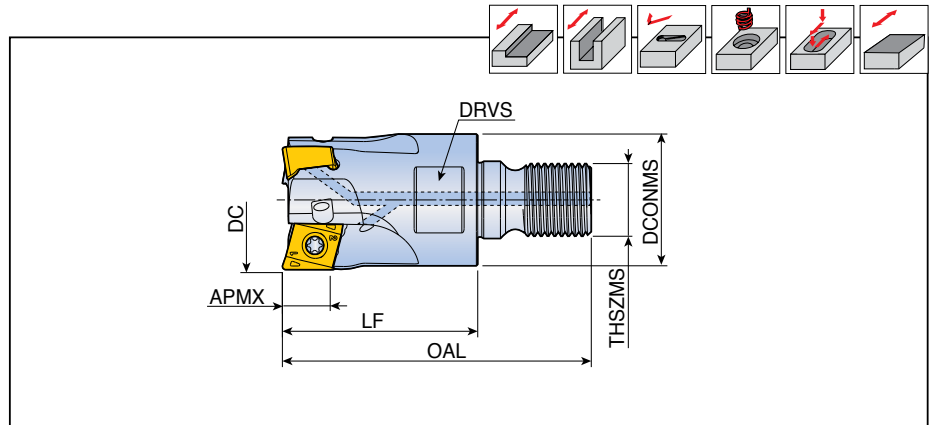
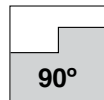
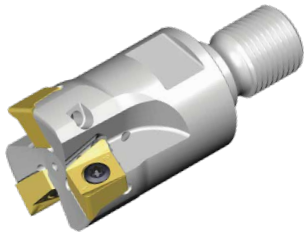

Designation	Z	Dimension (mm)							Coolant	Insert
		DC	DCONMS	LF	OAL	THSZMS	APMX	DRVS		
4N TE90- 225-M12-11	2	25	21	35	57	M12	10.5	17	●	4NKT 1106...
332-M16-11	3	32	29	43	68	M16	10.5	25	●	
440-M16-11	4	40	29	43	68	M16	10.5	25	●	

- Cutter body for '4NKT 110640R-HF' insert should be modified with body corner radius 4.0 mm
- Matched with T-FLEXTEC holder

Spare parts

Designation	Screw	Wrench	Wrench handle		
4N TE90-11	TS 40093I/HG	TBLD T15-W6	THND 6W		



4N TE90-14

End mills

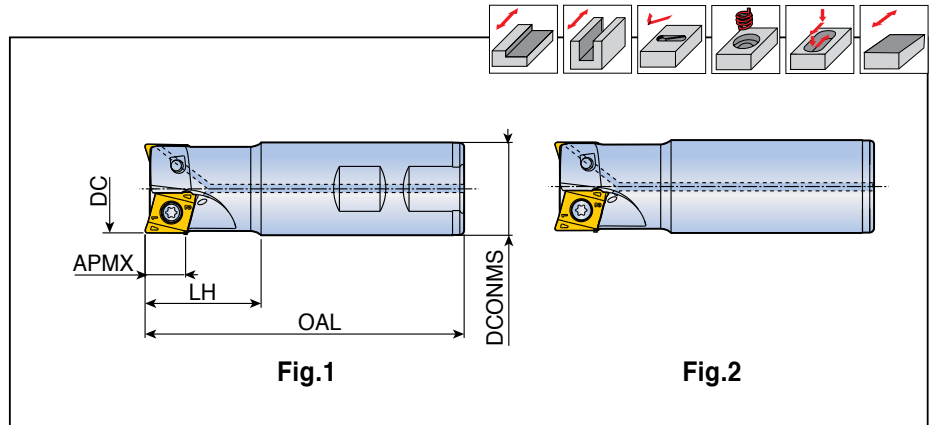
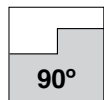

Designation	⌀	Dimension (mm)					Coolant	Fig.	Insert
		DC	DCONMS	OAL	LH	APMX			
4N TE90-232-W32-14	2	32	32	110	40	13.8	●	1	4NKT 1407...
232-32-14	2	32	32	150	45	13.8	●	2	
232-32-14-L250	2	32	32	250	40	13.8	●	2	
340-W32-14	3	40	32	115	40	13.8	●	1	
340-32-14	3	40	32	115	40	13.8	●	2	

• Cutter body for '4NKT 140750R-HF' insert should be modified with body corner radius 5.0 mm



4N TE90-M-14

Modular heads for T-FLEXTEC

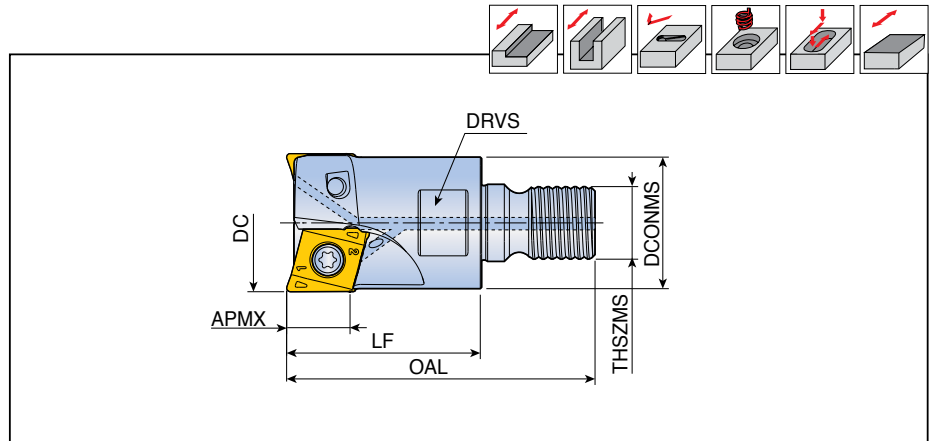
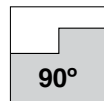

Designation		Dimension (mm)							Coolant	Insert
		DC	DCONMS	LF	OAL	THSZMS	APMX	DRVS		
4N TE90-232-M16-14	2	32	29	43	68	M16	13.8	25	●	4NKT 1407...
340-M16-14	3	40	29	43	68	M16	13.8	25	●	

- Cutter body for '4NKT 140750R-HF' insert should be modified with body corner radius 5.0 mm
- Matched with T-FLEXTEC holder

Spare parts

Designation	Screw	Wrench	Wrench handle		
4N TE90-14	TS 50A121I/HG	TBLD T20-W6	THND 6W		

4NK(H)T



Inserts

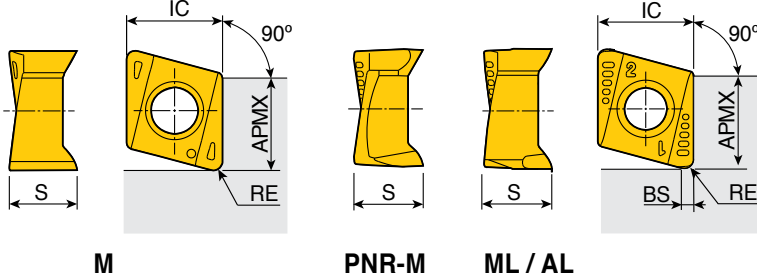

Size	Dimension (mm)				
	IC	S	APMX	BS	RE
04	4.0	3.1	3.5	-	0.2-0.8
09	8.6	5.7-6.3	8.0	0.8-1.2	0.4-1.6
11	10.7	8.1	10.5	1.0	0.8
14	14.0	9.2-9.4	13.5-13.8	1.25	0.8

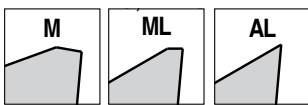

Insert	Designation	Recommended machining conditions		Coated							Uncoated	
		ap (mm)	Feed (mm/tooth)	TT9080	TT8080	TT8525	TT7515	TT7080	TT6080	TT2510	K10	
	4NKT 040202R-M	0.5-3.0	0.08-0.04	●	●							
	040204R-M	1.0-3.0	0.12-0.06	●	●				●			
	040208R-M	1.0-3.0	0.12-0.06	●	●							
	090408R-M	2.5-7.0	0.15-0.07	●	●		●		●	●		
	090416R-M	2.5-7.0	0.15-0.07	●	●				●			
	110608R-M	3.5-10.0	0.18-0.09	●	●				●			
	140708R-M	4.0-12.0	0.18-0.09	●	●	●		●	●			
	4NKT 110608 PNR-M	3.5-10.0	0.18-0.09	●	●	●						
	140708 PNR-M	4.0-12.0	0.18-0.09	●	●	●						
	4NHT 090404R-ML	2.5-7.0	0.10-0.04	●								
	090408R-ML	2.5-7.0	0.10-0.04	●	●							
	4NHT 090404R-AL	2.5-7.0	0.50-0.10									●
	090408R-AL	2.5-7.0	0.50-0.10									●

●: Standard items

4NKT-HF



High feed inserts

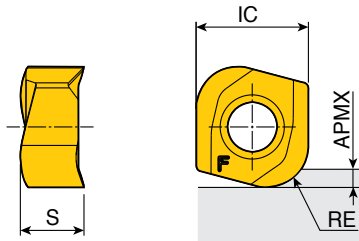

Size	Dimension (mm)				
	IC	S	APMX	RE	
04-HF	4.0	2.65	0.5	1.2	
06-HF	6.6	3.85	1.0	2.0	
09-HF	8.6	4.76	1.5	3.2	
11-HF	10.7	6.56	2.0	4.0	
14-HF	14.0	7.34	3.0	5.0	

Insert	Designation	Recommended machining conditions		Coated						Uncoated		
		ap (mm)	Feed (mm/tooth)	TT9080	TT8080	TT8525	TT7515	TT7080	TT6080	TT2510	K10	
	4NKT 040212R-HF	0.2-0.4	0.60-0.10	●						●		
	060320R-HF	0.2-0.6	0.80-0.20	●	●					●		
	090432R-HF	0.3-0.8	1.00-0.20	●								
	110640R-HF	0.3-1.2	1.20-0.30	●								
	140750R-HF	0.3-1.5	1.50-0.30	●								

●: Standard items

Ramping Data

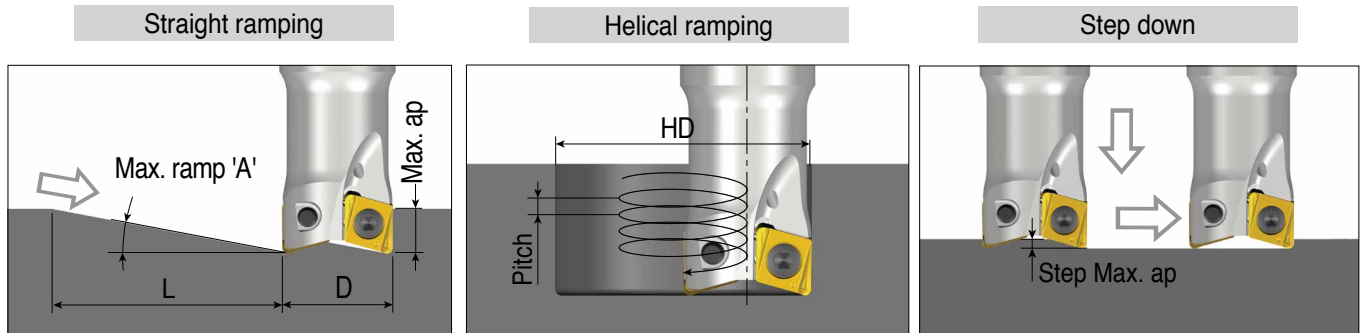

4NKT 04: R0.2

(unit: mm)

Cutter dia.(D)	Straight ramp down			Helical ramp down			Step down
	Max. ramp (A°)	Max. ap	Min. length (L)	Min. dia.(HD)	Max. dia.(HD)	Max. pitch/rev.	Max. ap
Ø8	4.2	3.5	48	9.9	16	0.4	0.4
Ø10	4.6	3.5	44	13.9	20	0.8	0.6
						2.1	
Ø11	5.2	3.5	38	15.9	22	1.2	0.7
						2.7	
Ø12	4.8	3.5	42	17.9	24	1.3	0.8
						2.7	
Ø13	5.1	3.5	39	19.9	26	1.6	0.8
						3.1	
Ø16	4.4	3.5	46	25.9	32	2.0	1.0
						3.3	
Ø20	3.3	3.5	61	33.9	40	2.1	1.0
						3.1	
Ø25	2.5	3.5	80	43.9	50	2.2	1.0
						2.9	
Ø32	1.9	3.5	106	57.9	64	2.3	1.0
						2.8	
Ø40	1.4	3.5	138	73.9	80	2.3	1.0
						2.7	

4NKT 04: R0.4

(unit: mm)

Cutter dia.(D)	Straight ramp down			Helical ramp down			Step down
	Max. ramp (A°)	Max. ap	Min. length (L)	Min. dia.(HD)	Max. dia.(HD)	Max. pitch/rev.	Max. ap
Ø8	3.7	3.5	54	9.9	16	0.3	0.4
						2.8	
Ø10	4.2	3.5	48	13.9	20	0.8	0.5
						2.0	
Ø11	4.8	3.5	42	15.9	22	1.1	0.6
						2.5	
Ø12	4.5	3.5	44	17.9	24	1.2	0.7
						2.5	
Ø13	4.7	3.5	43	19.9	26	1.5	0.8
						2.9	
Ø16	4.1	3.5	49	25.9	32	1.9	0.9
						3.1	
Ø20	3.1	3.5	65	33.9	40	2.0	0.9
						2.9	
Ø25	2.3	3.5	85	43.9	50	2.1	0.9
						2.7	
Ø32	1.7	3.5	115	57.9	64	2.1	0.9
						2.6	
Ø40	1.3	3.5	149	73.9	80	2.1	0.9
						2.5	

Ramping Data

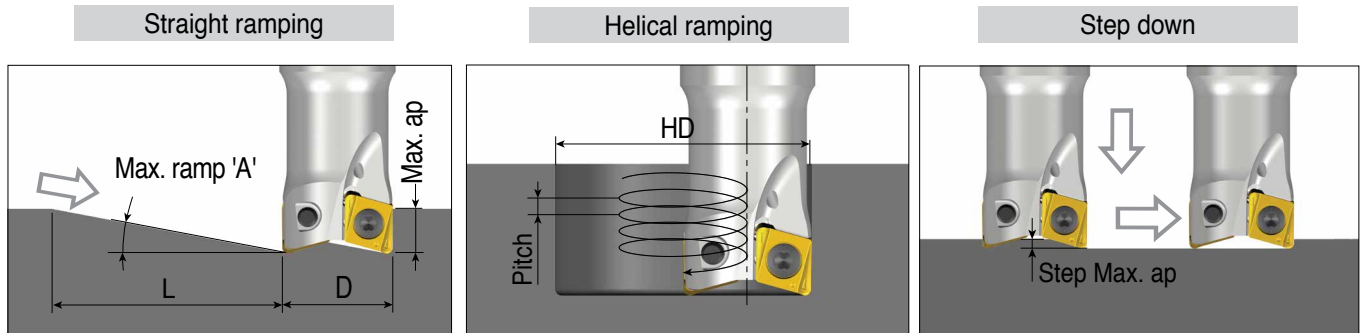

4NKT 04: R0.8

(unit: mm)

Cutter dia.(D)	Straight ramp down			Helical ramp down			Step down
	Max. ramp (A°)	Max. ap	Min. length (L)	Min. dia.(HD)	Max. dia.(HD)	Max. pitch/rev.	Max. ap
Ø8	2.2	3.5	91	9.9		0.2	0.2
					16	1.6	
Ø10	3.0	3.5	67	13.9		0.5	0.4
					20	1.4	
Ø11	3.7	3.5	54	15.9		0.8	0.5
					22	1.9	
Ø12	3.5	3.5	57	17.9		1.0	0.5
					24	2.0	
Ø13	3.9	3.5	51	19.9		1.3	0.6
					26	2.4	
Ø16	3.5	3.5	57	25.9		1.6	0.7
					32	2.6	
Ø20	2.6	3.5	77	33.9		1.7	0.7
					40	2.4	
Ø25	1.9	3.5	103	43.9		1.7	0.7
					50	2.3	
Ø32	1.5	3.5	134	57.9		1.8	0.7
					64	2.2	
Ø40	1.1	3.5	174	73.9		1.8	0.7
					80	2.1	

Ramping Data

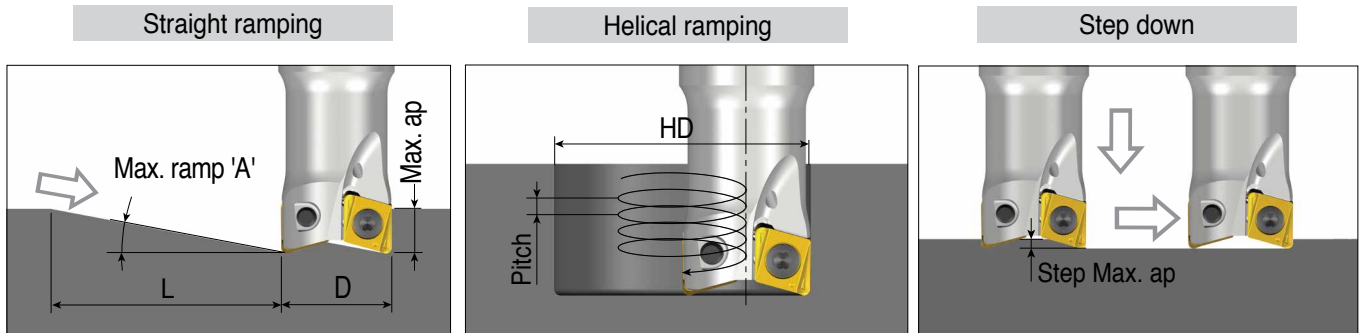

4NKT 09: R0.8

(unit: mm)

Cutter dia.(D)	Straight ramp down			Helical ramp down			Step down
	Max. ramp (A°)	Max. ap	Min. length (L)	Min. dia.(HD)	Max. dia.(HD)	Max. pitch/rev.	Max. ap
Ø20	3.7	8.0	124	25.5	40	0.9	1.0
						3.5	
Ø25	4.9	8.0	93	35.5	50	2.4	1.6
						5.7	
Ø32	4.9	8.0	93	49.5	64	4.0	2.1
						7.3	
Ø40	3.6	8.0	127	65.5	80	4.3	2.1
						6.7	
Ø50	2.7	8.0	170	85.5	100	4.5	2.1
						6.3	
Ø63	2.0	8.0	224	111.5	126	4.6	2.1
						6.0	
Ø80	1.5	8.0	296	145.5	160	4.7	2.1
						5.8	

4NKT 09: R1.6

(unit: mm)

Cutter dia.(D)	Straight ramp down			Helical ramp down			Step down
	Max. ramp (A°)	Max. ap	Min. length (L)	Min. dia.(HD)	Max. dia.(HD)	Max. pitch/rev.	Max. ap
Ø20	2.7	8.0	167	25.5	40	0.7	0.7
						2.6	
Ø25	4.1	8.0	112	35.5	50	2.0	1.3
						4.8	
Ø32	4.4	8.0	104	49.5	64	3.6	1.8
						6.6	
Ø40	3.1	8.0	148	65.5	80	3.7	1.8
						5.8	
Ø50	2.3	8.0	195	85.5	100	3.9	1.8
						5.5	
Ø63	1.8	8.0	255	111.5	126	4.1	1.8
						5.3	
Ø80	1.3	8.0	340	145.5	160	4.1	1.8
						5.0	

Ramping Data

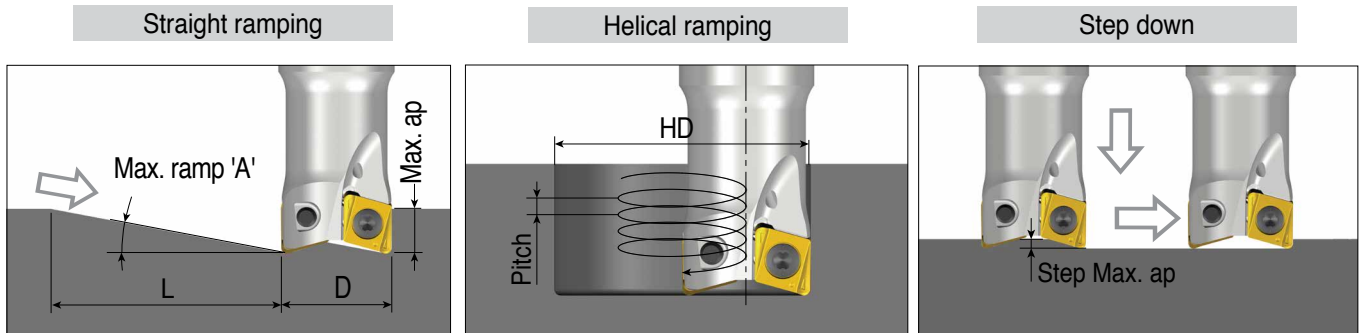

4NHT 09: R0.4

(unit: mm)

Cutter dia.(D)	Straight ramp down			Helical ramp down			Step down
	Max. ramp (A°)	Max. ap	Min. length (L)	Min. dia.(HD)	Max. dia.(HD)	Max. pitch/rev.	Max. ap
Ø20	2.9	8.0	155	25.5		0.8	0.8
					40	2.7	
Ø25	4.3	8.0	106	35.5		2.1	1.3
					50	5.0	
Ø32	4.5	8.0	102	49.5		3.7	1.8
					64	6.7	
Ø40	3.2	8.0	143	65.5		3.8	1.8
					80	6.0	
Ø50	2.4	8.0	191	85.5		4.0	1.8
					100	5.6	
Ø63	1.8	8.0	255	111.5		4.1	1.8
					126	5.3	
Ø80	1.3	8.0	340	145.5		4.1	1.8
					160	5.0	

4NHT 09: R0.8

(unit: mm)

Cutter dia.(D)	Straight ramp down			Helical ramp down			Step down
	Max. ramp (A°)	Max. ap	Min. length (L)	Min. dia.(HD)	Max. dia.(HD)	Max. pitch/rev.	Max. ap
Ø20	2.9	8.0	155	25.5		0.8	0.8
					40	2.7	
Ø25	4.3	8.0	106	35.5		2.1	1.3
					50	5.0	
Ø32	4.5	8.0	102	49.5		3.7	1.8
					64	6.7	
Ø40	3.2	8.0	143	65.5		3.8	1.8
					80	6.0	
Ø50	2.4	8.0	191	85.5		4.0	1.8
					100	5.6	
Ø63	1.8	8.0	255	111.5		4.1	1.8
					126	5.3	
Ø80	1.3	8.0	340	145.5		4.1	1.8
					160	5.0	

Ramping Data

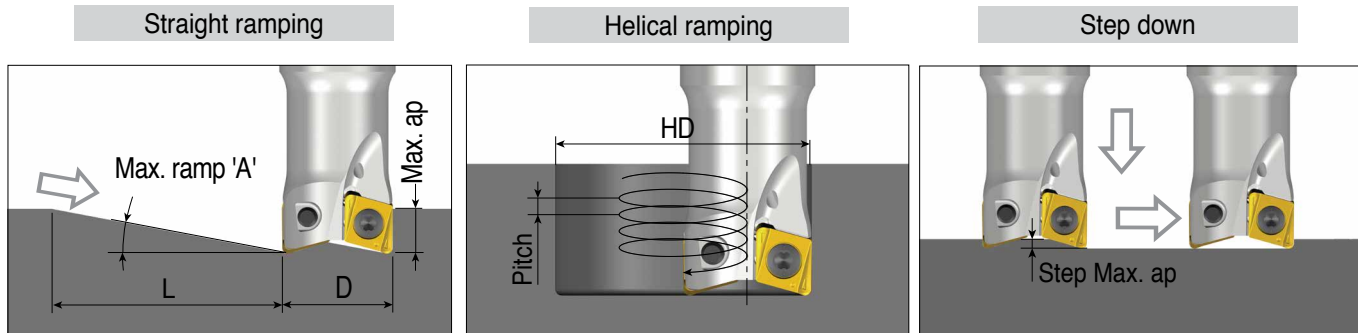

4NKT 11: R0.8

(unit: mm)

Cutter dia.(D)	Straight ramp down			Helical ramp down			Step down
	Max. ramp (A°)	Max. ap	Min. length (L)	Min. dia.(HD)	Max. dia.(HD)	Max. pitch/rev.	Max. ap
Ø25	5.1	10.3	115	31.5	50	1.5 6.0	1.7
Ø32	5.3	10.3	111	45.5	64	3.3 7.9	2.4
Ø40	5.0	10.3	118	61.5	80	5.0 9.3	2.7
Ø50	3.7	10.3	159	81.5	100	5.4 8.6	2.7
Ø63	2.7	10.3	219	107.5	126	5.6 7.9	2.7
Ø80	2.0	10.3	288	141.5	160	5.9 7.6	2.7

4NKT 14: R0.8

(unit: mm)

Cutter dia.(D)	Straight ramp down			Helical ramp down			Step down
	Max. ramp (A°)	Max. ap	Min. length (L)	Min. dia.(HD)	Max. dia.(HD)	Max. pitch/rev.	Max. ap
Ø32	5.2	13.5	148	39.5	64	1.8 7.8	2.3
Ø40	5.2	13.5	148	55.5	80	3.8 9.7	3.0
Ø50	5.5	13.5	140	75.5	100	6.6 12.8	3.3
Ø63	4.0	13.5	193	101.5	126	7.2 11.8	3.3
Ø80	2.9	13.5	267	135.5	160	7.5 10.8	3.3

Ramping Data

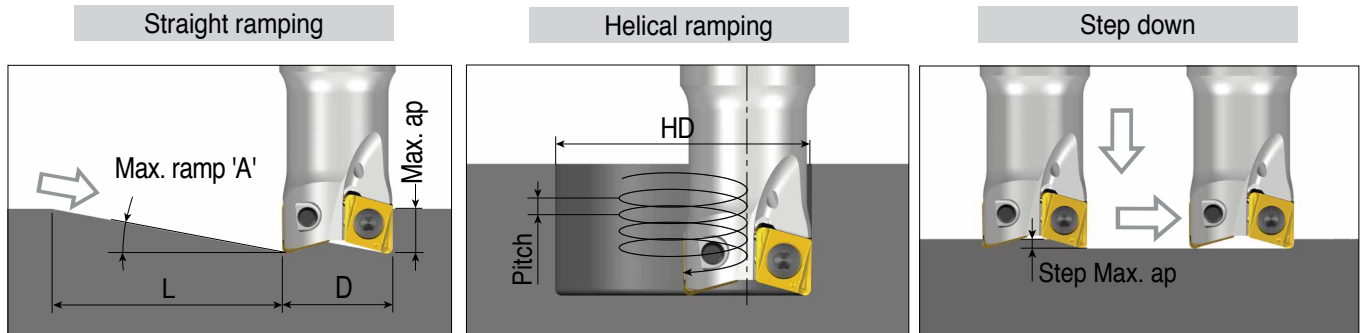

4NKT 11 PNR: R0.8

(unit: mm)

Cutter dia.(D)	Straight ramp down			Helical ramp down			Step down
	Max. ramp (A°)	Max. ap	Min. length (L)	Min. dia.(HD)	Max. dia.(HD)	Max. pitch/rev.	Max. ap
Ø25	4.0	10.3	147	31.5	50	1.2	1.1
Ø32	4.3	10.3	135	45.5	64	2.7	1.0
Ø40	4.5	10.3	131	61.5	80	4.5	0.9
Ø50	3.2	10.3	184	81.5	100	4.7	0.9
Ø63	2.4	10.3	246	107.5	126	5.0	0.9
Ø80	1.8	10.3	328	141.5	160	5.2	0.9

4NKT 14 PNR: R0.8

(unit: mm)

Cutter dia.(D)	Straight ramp down			Helical ramp down			Step down
	Max. ramp (A°)	Max. ap	Min. length (L)	Min. dia.(HD)	Max. dia.(HD)	Max. pitch/rev.	Max. ap
Ø32	4.1	13.5	188	39.5	64	1.4	1.1
Ø40	4.3	13.5	180	55.5	80	3.1	0.9
Ø50	4.7	13.5	163	75.5	100	5.7	0.9
Ø63	3.5	13.5	221	101.5	126	6.3	0.9
Ø80	2.6	13.5	297	135.5	160	6.7	0.9

Ramping Data

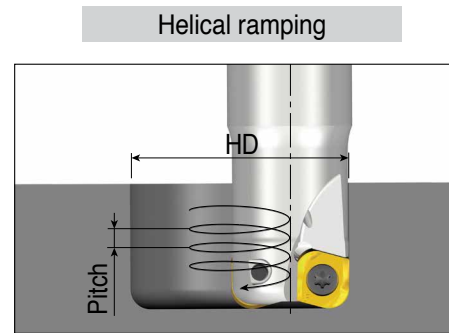
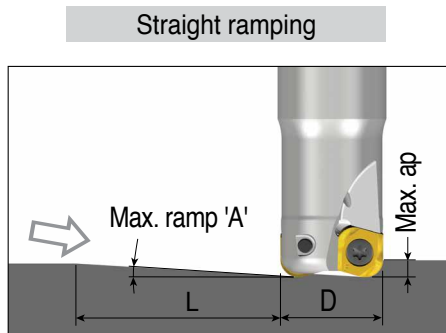

4NKT 04-HF: R1.2

(unit: mm)

Cutter dia.(D)	Straight ramp down			Helical ramp down		
	Max. ramp (A°)	Max. ap	Min. length (L)	Min. dia.(HD)	Max. dia.(HD)	Max. pitch/rev.
Ø8	0.1	0.5	191	9.9	16	0.0
Ø10	0.8	0.5	34	13.9	20	0.2
						0.4
Ø11	1.6	0.5	18	15.9	22	0.4
						0.5
Ø12	1.6	0.5	18	17.9	24	0.4
						0.5
Ø13	2.0	0.5	14	19.9	26	0.5
						0.5
Ø16	1.9	0.5	15	25.9	32	0.5
						0.5
Ø20	2.3	0.5	12	33.9	40	0.5
						0.5
Ø25	1.7	0.5	16	43.9	50	0.5
						0.5
Ø32	1.3	0.5	22	57.9	64	0.5
						0.5
Ø40	1.0	0.5	29	73.9	80	0.5
						0.5

4NKT 06-HF: R2.0

(unit: mm)

Cutter dia.(D)	Straight ramp down			Helical ramp down		
	Max. ramp (A°)	Max. ap	Min. length (L)	Min. dia.(HD)	Max. dia.(HD)	Max. pitch/rev.
Ø16	0.6	1.0	88	21.4	32	0.2
						0.5
Ø17	0.7	1.0	76	23.4	34	0.2
						0.6
Ø18	1.1	1.0	50	25.4	36	0.4
						1.0
Ø20	1.7	1.0	34	29.4	40	0.7
						1.0
Ø21	1.9	1.0	29	31.4	42	0.9
						1.0
Ø25	2.3	1.0	24	39.4	50	1.0
						1.0
Ø26	3.2	1.0	18	41.4	52	1.0
						1.0
Ø32	2.4	1.0	24	53.4	64	1.0
						1.0
Ø40	1.8	1.0	32	69.4	80	1.0
						1.0
Ø50	1.4	1.0	41	89.4	100	1.0
						1.0
Ø63	1.1	1.0	52	115.4	126	1.0
						1.0

Ramping Data

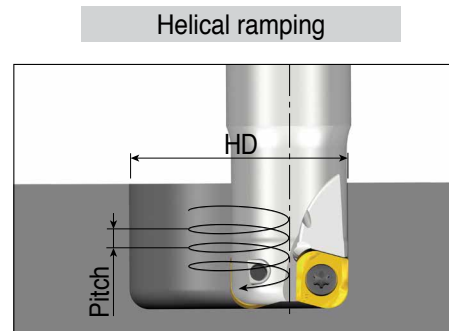
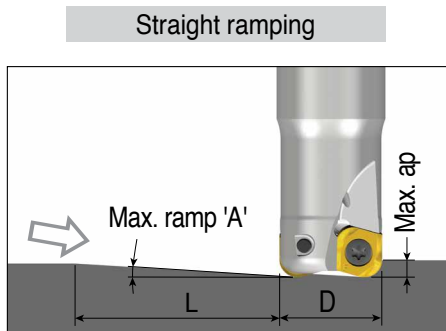

4NKT 09-HF: R3.2

(unit: mm)

Cutter dia.(D)	Straight ramp down			Helical ramp down		
	Max. ramp (A°)	Max. ap	Min. length (L)	Min. dia.(HD)	Max. dia.(HD)	Max. pitch/rev.
Ø20	0.3	1.5	287	25		0.1
					40	0.3
Ø25	1.2	1.5	69	35		0.6
					50	1.5
Ø32	2.4	1.5	35	49		1.5
					64	1.5
Ø40	2.3	1.5	37	65		1.5
					80	1.5
Ø50	1.7	1.5	49	85		1.5
					100	1.5
Ø63	1.3	1.5	66	111		1.5
					126	1.5
Ø80	1.0	1.5	86	145		1.5
					160	1.5

4NKT 11-HF: R4.0

(unit: mm)

Cutter dia.(D)	Straight ramp down			Helical ramp down		
	Max. ramp (A°)	Max. ap	Min. length (L)	Min. dia.(HD)	Max. dia.(HD)	Max. pitch/rev.
Ø25	0.8	2.0	143	31		0.2
					50	0.9
Ø32	2.0	2.0	57	45		1.2
					64	2.0
Ø40	3.4	2.0	34	61		2.0
					80	2.0
Ø50	2.4	2.0	48	81		2.0
					100	2.0
Ø63	1.8	2.0	64	107		2.0
					126	2.0
Ø80	1.3	2.0	85	141		2.0
					160	2.0

Ramping Data

Straight ramping

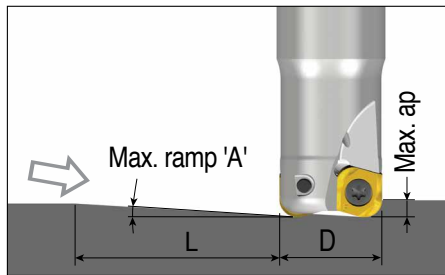

Helical ramping

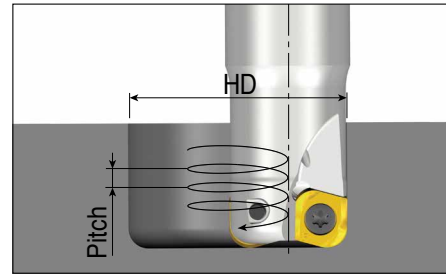

4NKT 14-HF: R5.0

(unit: mm)

Cutter dia.(D)	Straight ramp down			Helical ramp down		
	Max. ramp (A°)	Max. ap	Min. length (L)	Min. dia.(HD)	Max. dia.(HD)	Max. pitch/rev.
Ø32	1.0	3.0	172	39	64	0.3
						1.5
Ø40	1.8	3.0	96	55	80	1.3
						3.0
Ø50	3.9	3.0	44	75	100	3.0
						3.0
Ø63	2.7	3.0	64	101	126	3.0
						3.0
Ø80	1.9	3.0	88	135	160	3.0
						3.0

Programming technical data

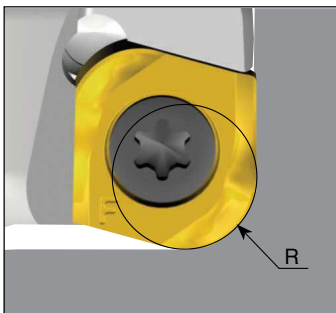

	R Program	A Over cut	B Un-machined
4NKT 040212R-HF	1.2	0	0
4NKT 060320R-HF	2.0	0	0
4NKT 090432R-HF	3.2	0	0
4NKT 110640R-HF	4.0	0	0
4NKT 140750R-HF	5.0	0	0

KIT COLLECTIONS

These kit products are available in the format listed below.



Cat. No.	Designation	Bill of materials	Qty.
6334772	KISFT-4N-TE90-210-04	4N TE90-210-10-04	1
		4NKT 040204R-M TT9080	4
6334773	KISFT-4N-TE90-312-04	4N TE90-312-12-04	1
		4NKT 040204R-M TT9080	6
6334774	KISFT-4N-TE90-416-04	4N TE90-416-W16-04	1
		4NKT 040204R-M TT9080	8
6334775	KISFT-4N-TE90-325-09	4N TE90-325-W25-09	1
		4NKT 090408R-M TT9080	6
6334776	KISFT-4N-TE90-432-09	4N TE90-432-W32-09	1
		4NKT 090408R-M TT9080	8
6334777	KISFT-4N-TF90-540-09	4N TF90-540-16R-09	1
		4NKT 090408R-M TT9080	10



Cat. No.	Designation	Bill of materials	Qty.
6337838	KISFS-4N-TE90-210-04	4N TE90-210-10-04	1
		4NKT 040204R-M TT9080	50
6337839	KISFS-4N-TE90-312-04	4N TE90-312-12-04	1
		4NKT 040204R-M TT9080	50
6337840	KISFS-4N-TE90-416-04	4N TE90-416-W16-04	1
		4NKT 040204R-M TT9080	50
6337841	KISFS-4N-TE90-325-09	4N TE90-325-W25-09	1
		4NKT 090408R-M TT9080	50
6337842	KISFS-4N-TE90-432-09	4N TE90-432-W32-09	1
		4NKT 090408R-M TT9080	50
6337843	KISFS-4N-TF90-540-09	4N TF90-540-16R-09	1
		4NKT 090408R-M TT9080	50



Cat. No.	Designation	Bill of materials	Qty.
6338418	KISFF-A-4NKT 04-M TT9080	4NKT 040204R-M TT9080	100
6338419	KISFF-B-4NKT 04-M TT9080		300
6338420	KISFF-C-4NKT 04-M TT9080		500
6338421	KISFF-A-4NKT 09-M TT9080	4NKT 090408R-M TT9080	100
6338422	KISFF-B-4NKT 09-M TT9080		300
6338423	KISFF-C-4NKT 09-M TT9080		500